

# **EASIDEW PRO I.S. HYGROMETER**

## **INSTALLATION, OPERATION AND MAINTENANCE MANUAL**

Issue April 2011

---

**KAHN INSTRUMENTS, INC.**

885 Wells Road, Wethersfield, CT 06109  
Tel: 860-529-8643; Fax: 860-529-1895  
E-mail: [info@kahn.com](mailto:info@kahn.com)  
[www.kahn.com](http://www.kahn.com)

## TABLE OF CONTENTS

<u>SECTION</u>	<u>PAGE</u>
1. INTRODUCTION	5
1.1 General	5
1.2 EASIDEW PRO I.S. Hygrometer Overview	5
1.3 EASIDEW PRO I.S. TRANSMITTER Overview	6
1.4 Galvanic Isolation Interface Overview	7
1.5 Outline of Complete System	8
1.6 Calibration	9
1.7 Manufacturing Quality	9
2. PREPARING EASIDEW PRO I.S. MONITOR FOR USE	10
2.1 Installing the Monitor	10
2.2 Electrical Connections	11
<b>2.2.1 Electrical Power</b>	13
<b>2.2.2 Setpoint (Alarm) Relays</b>	14
<b>2.2.3 Analog Output</b>	14
<b>2.2.4 Digital Interface</b>	14
3. EASIDEW PRO I.S. TRANSMITTER	15
3.1 EASIDEW PRO I.S. Transmitter Identification	15
3.2 Mechanical Installation	15
3.3 Operating Precautions	18
3.4 Sampling Hints	18
3.5 Response Characteristics	19
3.6 Which Gases to Measure	19
3.7 Maintaining the EASIDEW PRO I.S. Transmitter	20

4.	EASIDEW PRO I.S. CABLE CONNECTION	21
4.1	Cable Connection	21
4.2	Preparation of the Sensor Cable	21
4.3	Cable Screen Termination	23
4.4	Installation in Hazardous Areas	23
5.	CONNECTING EASIDEW PRO I.S. TO THE MONITOR	24
6.	EASIDEW PRO I.S. MONITOR SETUP	25
6.1	Setup Security Feature	25
6.2	Selecting the Engineering Units	26
6.3	Changing the Setpoint Values	26
6.4	Analog Output Scaling	28
6.5	Display Brightness Adjustment	29
6.6	Digital Communications	29
7.	PRESSURE COMPENSATION	31
7.1	Using a Pressure Transmitter	31
7.2	Using a Fixed Pressure Input in Single Channel Mode	32
7.3	Pressure Transmitter Connection	32
8.	MONITOR MAINTENANCE	33
9.	TECHNICAL SPECIFICATIONS	34
9.1	EASIDEW PRO I.S. Monitor	34
9.2	EASIDEW PRO I.S. Transmitter	35

<b><u>FIGURES</u></b>	<b><u>PAGES</u></b>
FIGURE 1. COMPLETE SYSTEM	8
FIGURE 2. PANEL CUTOUT	11
FIGURE 3. CASE DIMENSIONS	11
FIGURE 4. INSTRUMENT WIRING DIAGRAM	12
FIGURE 5. MONITOR ELECTRICAL CONNECTION	13
FIGURE 6. EASIDEW PRO I.S. TRANSMITTER DIMENSIONS	17
FIGURE 7. SENSOR CABLE PREPARATION	21
FIGURE 8. LOCATION OF THE LOCKOUT SWITCHCES	25
FIGURE 9. SYSTEM WIRING AND ISOLATION BARRIER INSTALLATION	36

<b><u>ATTACHMENTS</u></b>	<b><u>PAGES</u></b>
ATTACHMENT 1	37
ATTACHMENT 2	39
ATTACHMENT 3	43

# 1. INTRODUCTION

## 1.1 General

Kahn Instruments manufactures a wide range of on-line and portable instruments for the determination of moisture content in air and gases. In addition, the company manufactures humidity calibration systems for industrial and scientific users.

The EASIDEW PRO I.S. Hygrometer utilizes the intrinsically safe EASIDEW PRO I.S. Process Dewpoint Transmitter as the sensor coupled with the EASIDEW PRO I.S. advanced monitor as the display unit.

## 1.2 EASIDEW PRO I.S. Hygrometer Overview

The EASIDEW PRO I.S. Hygrometer is a continuous, on-line instrument for the measurement of absolute moisture content in flammable or non-flammable gases in hazardous areas utilizing an intrinsically safe dewpoint sensor and a safe area panel-mounted digital display. It is designed to fulfill a wide range of applications and provide for the monitoring and/or control of moisture in non-corrosive gases. The Easidew PRO I.S. Hygrometer consists of three component parts: EASIDEW PRO I.S. Process Dewpoint Transmitter as the sensor, Monitor and Galvanic Isolation Interface. The monitor and sensor are individually calibrated to a single standard allowing combinations of sensor (EASIDEW PRO I.S. Dewpoint Transmitter) and monitor to be totally interchangeable.

The standard instrument covers the ranges -148°F dewpoint to +68°F dewpoint (-100°C dewpoint to +20°C dewpoint), 0 to 9999 parts per million by volume (ppmV), as well as 0 to 1000 LB/MMSCF and  $\text{g/m}^3$  for natural gas. Selection of the displayed hygrometric unit is factory set but may be easily changed by the user. Dual alarm relay contacts (Form C type) are provided which are user configurable both in terms of setpoint and operating mode. Optionally, 1 or 2 additional relays can be supplied with Form A type contacts (see section 2.2.2 for details). Isolated current output is standard and factory set at 4 to 20mA; optional output is 0 to 10 VDC.

The monitor can be supplied with an optional pressure input channel to accept the signal from any loop-powered intrinsically safe 2-wire pressure transmitter. Pressure can be scaled and displayed to appropriate engineering units. The pressure signal can then be used to provide automatic pressure compensation on the primary channel of LB/MMSCF,  $\text{g/m}^3$  or ppmV.

### 1.3 EASIDEW PRO I.S. TRANSMITTER Overview

**The Intrinsically Safe EASIDEW PRO I.S. Dewpoint Transmitter measures dewpoint over the range -148°F to +68°F (-100°C to +20°C). It is designed for use within the following hazardous areas: Class I, Division 1, Groups A, B, C & D T4 when used with the appropriate isolation barrier.**

The EASIDEW PRO I.S. Transmitter utilizes a Ceramic Moisture Sensor manufactured from metalized ceramics using thin and thick film technologies. The Kahn ceramic moisture sensor is virtually chemically inert with inherently fast response, high calibration stability and high resilience to corrosive environments. EASIDEW PRO I.S. Transmitter measures humidity by monitoring the electrical response exhibited by the sensor to variations in partial pressure of water vapor of the gas composition to which it is exposed.

The EASIDEW PRO I.S. Transmitter is connected as a 2-wire, loop-powered transmitter with a 4 to 20 mA current source output. This output is linear over the entire dewpoint measurement range from -148°F to +68°F (-100°C to +20°C).

The EASIDEW PRO I.S. Transmitter is approved as an intrinsically safe device for use in hazardous locations when used with appropriate isolation barrier(s).

#### **Factory Mutual Research Corporation (FM)**

The EASIDEW PRO I.S. Transmitter conforms to the Approval Standard FM3600 (1998), FM3610 (2007) and FM3810 (2005), and carries the following marking code: Intrinsically Safe for Class I, Division 1, Groups A, B, C & D (Classified) locations when installed in accordance with Entity Concept and Control Drawing Ex90385. FM Certificate Number: 3030328.

#### **Canadian Standards Association (CSA)**

The Easidew PRO I.S. Transmitter conforms to the following Standards: CANCSA 22.2 No. 0-M91 (R2006), CAN/CSA-C22.2 No. 157-92 (R2006) and CAN/CSA No.142-M1987 (R2004) and carries the Hazardous Area designation: Intrinsically Safe Class I, Division I, Group A, B, C and D, T4. CSA Certificate Number: 2013218.

#### **ATEX and IEC**

The Easidew PRO I.S. Transmitter is certified to the ATEX Directive (94/9/EC) and IECEx for safe use within a hazardous area and has been assessed so by Baseefa 2001 Ltd (Notified Body 1180). This product conforms to the Standards EN60079-0:2004, EN50020:2002, IEC60079-0:2004, IEC60079-11:1999 and is attributed with a product certification code: II 1 G Ex ia IIC T4 Tamb -20°C to +60°C. ATEX Certificate Number: BAS06ATEX0330X/1, ATEX System Certificate Number: Baseefa 07Y0027/2 and IEC Certificate Number IECEx BAS 06.0090X Iss01.

Before using the EASIDEW PRO I.S. in any hazardous environment, be sure you are fully familiar with the above Factory Mutual or CSA standards relating to the certification of this instrument and also with the further information relating to intrinsically safe apparatus to be found in Article 504 in the National Electrical Code, ANSI/NFPA 70 or equivalent codes of practice in the country of installation.

**WARNING: SUBSTITUTION OF COMPONENTS MAY IMPAIR INTRINSIC SAFETY.**

## **1.4 Galvanic Isolation Interface Overview**

The galvanic isolation interface consists of the galvanic isolation safety barrier. The isolation barrier limits the electrical-spark energy that can arise in hazardous areas to levels that are not sufficient to ignite an explosive atmosphere and galvanically isolate the hazardous area circuitry from safe area circuitry. The galvanic isolation interface must be installed in the safe (non-hazardous area).

## 1.5 Outline of Complete System

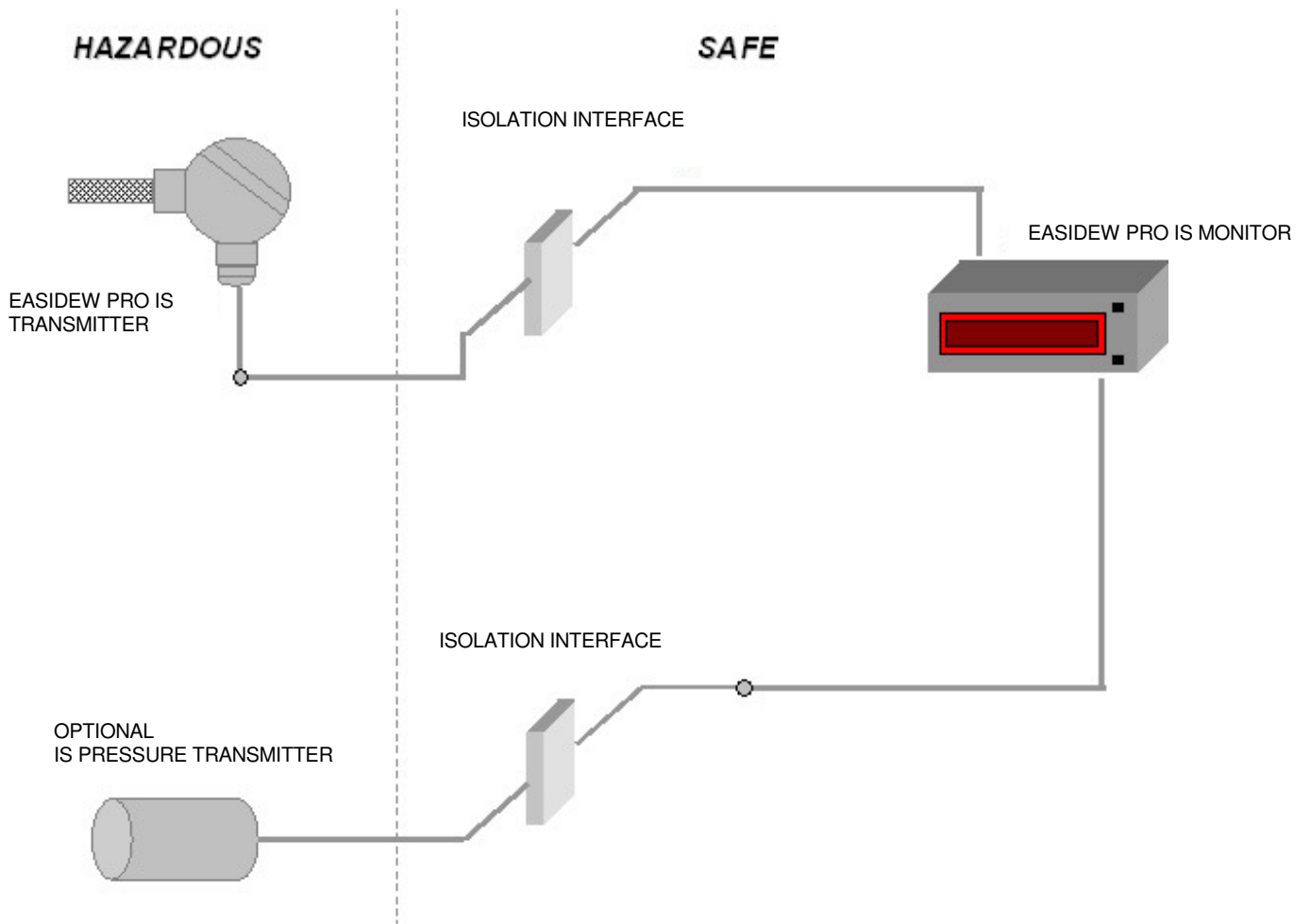

Figure 1. Complete System

## 1.6 Calibration

Calibrations are performed using precision dewpoint generators and transfer standard optical hygrometers, which have been calibrated directly at the National Institute of Standards & Technology (**NIST**) Gaithersburg, MD, USA.

## 1.7 Manufacturing Quality

Your instrument should reach you in perfect working condition. We have rigorous procedures at every stage of production to ensure that the materials of construction, manufacturing, calibration and final test procedures meet the requirements laid down by our Quality System.

## 2. PREPARING EASIDEW PRO I.S. MONITOR FOR USE

The EASIDEW PRO I.S. Hygrometer is supplied with a full accessory package. Please check that all the items indicated on the packing checklist are present in the delivery.

**NOTE:** The EASIDEW PRO I.S. Monitor is NOT in itself INTRINSICALLY SAFE and therefore must not be installed in the hazardous area. Install the monitor and the Galvanic Isolation Interface in the non-hazardous (safe) area.

### 2.1 Installing the Monitor

The monitor can operate within the environment limits of +32°F to +122°F (0°C to 50°C), 0 to 90% RH.

The monitor case is designed for panel mounting. However, it can be used as a bench mounted device without any special preparation.

For panel mounting, a suitable cutout should be made in the panel to be used. A 1/8 DIN rectangular cutout of 3.62" wide 1.77" high (92 x 45mm) is necessary (see Figure 2. Panel Cutout). An Optional NEMA 4 cover provides additional front panel protection for harsh environments. The monitor may also be installed in an optional NEMA 4 enclosure with NEMA 4 front cover.

**NOTE:** A minimum depth behind the panel of 5.5" is required for the monitor, its connectors and wiring (see Figure 3. Case Dimensions).

The monitor should be inserted into the panel cutout from the front and secured using the two brackets with securing screws on the sides of the front case.

All electrical connections through the rear panel are made via plug and socket terminals to facilitate easy removal of the monitor when in service (see Figure 5. Monitor Electrical Connection).

## 2.1 Installing the Monitor (Continued)



Figure 2. Panel Cutout

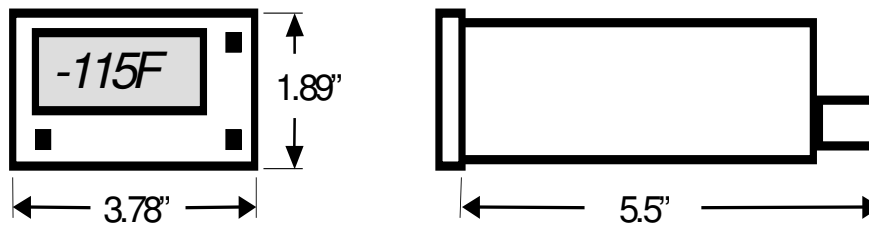

Figure 3. Case Dimensions

## 2.2 Electrical Connections

When the monitor is securely fastened in position, the electrical connections can be made to the back panel.

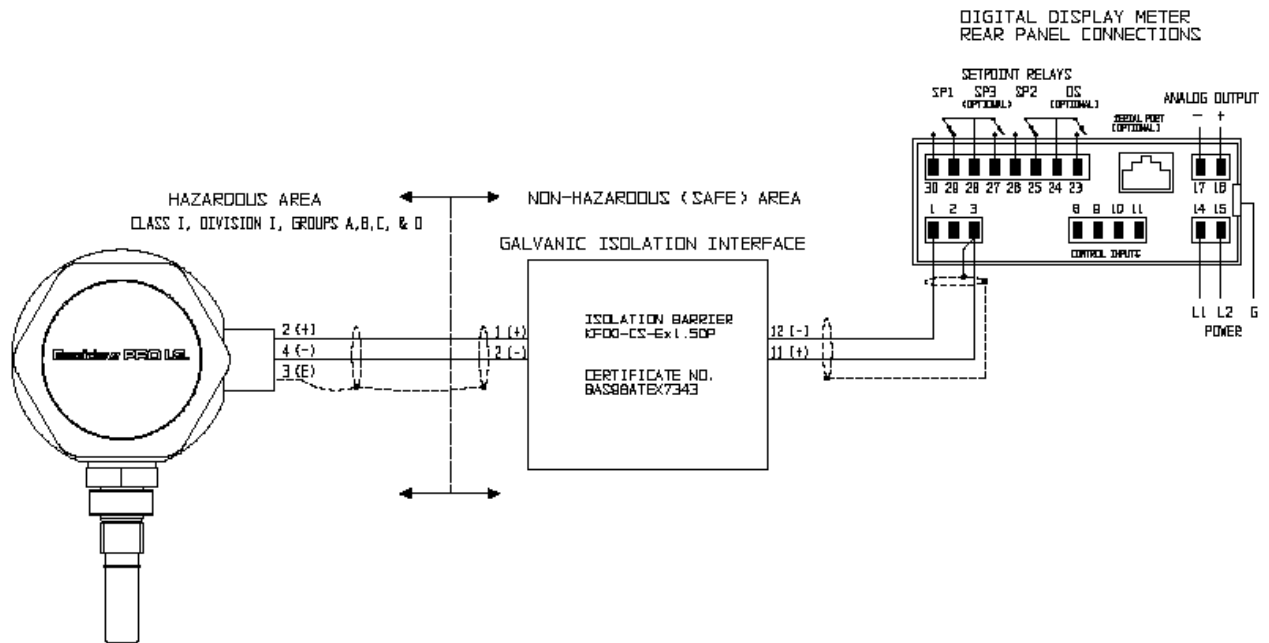

Figure 4. Instrument Wiring Diagram

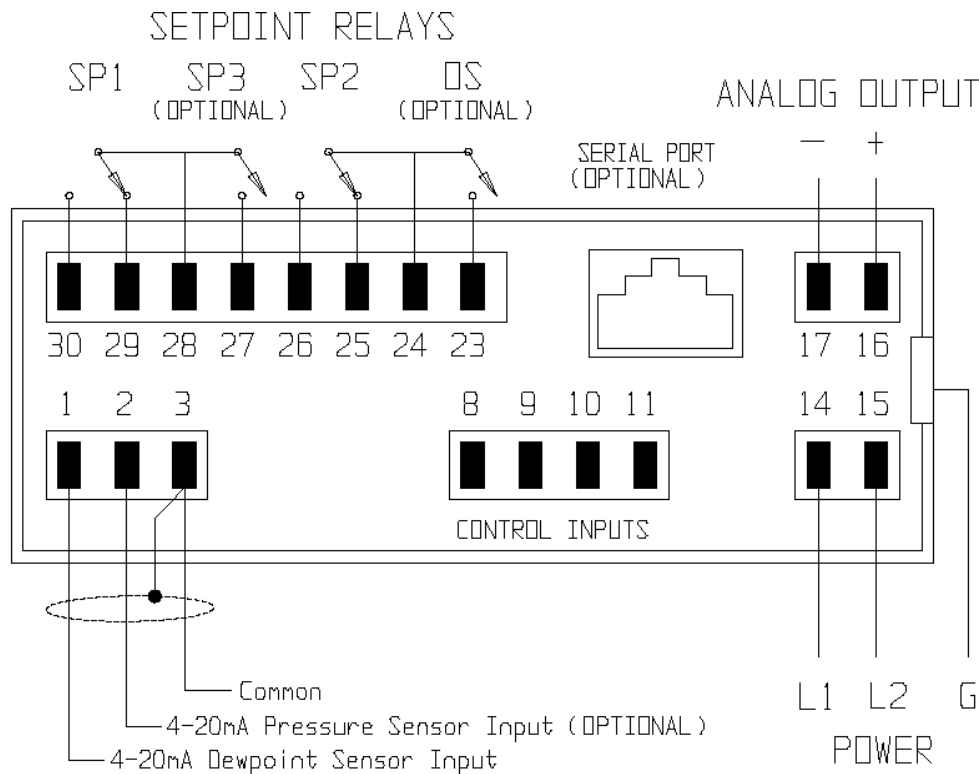

Figure 5. Monitor Electrical Connection

Figure 5 above shows the connections for power, dewpoint sensor, optional pressure sensor, alarm relays and analog output. These details are also repeated on the label attached to the monitor. The exact factory setup of the monitor can also be obtained by reference to the label applied to the monitor case.

### 2.2.1 Electrical Power

The power supply to the monitor may be one of the following:

- a) 85-265 VAC 50/60Hz - **factory default setting**
- b) 18-36 VAC and 9-60VDC - **optional**

The power supply voltage is indicated on the connection details label located on the monitor.

As soon as power is connected at the rear of the monitor, the display will register a reading. The monitor is provided for continuous operation and does not feature a power ON/OFF switch.

## 2.2.2 Setpoint (Alarm) Relays

SP1 and SP2 are Form C (single pole, changeover) relay contacts and can be connected as Normally Open or Normally Closed. Connections are NO - Normally Open, NC - Normally Closed and COM - common. Contacts are rated 240 VAC, 10A or 24 VDC, 8A (non-inductive load).

Optional additional relays SP3 and Open Sensor (OS) have Form A (single pole, normally closed) relay contacts and are Normally Closed only. Connections are NC - normally closed and COM - common. Contacts are rated 240 VAC, 5A or 30VDC, 5A (non-inductive load).

Configuration of setpoints for operation as under \ over range or band limit is covered in section 7.3.

## 2.2.3 Analog Output

The monitor as standard provides an isolated 4 to 20 mA (optionally 0-10 VDC) linear output over the entire operating range of the instrument in the selected engineering units. The output can be digitally scaled to cover a partial range of the measurement parameter. See **CAL** (under setup codes) in appendix 2.

The maximum load resistance that can be connected between pin 16(+) and pin 17(-) for a **CURRENT** output is 500 Ohms (No minimum).

The minimum load that can be connected to pin 16(+) and pin 17(-) for a **VOLTAGE** output is 5 kOhms (No maximum).

## 2.2.4 Digital Interface

The monitor can be supplied with an optional RS232 or RS485 digital interface. A 6-foot RS232 cable, terminated with 9 pin "D" connector, is available on request.

## **3. EASIDEW PRO I.S. TRANSMITTER**

### **3.1 EASIDEW PRO I.S. Transmitter Identification**

A serial number label located on the outside of the EASIDEW PRO I.S. Transmitter housing can identify the EASIDEW PRO I.S. Transmitter. The label also describes the I.S. certification code for EASIDEW PRO I.S. Transmitter.

### **3.2 Mechanical Installation**

The EASIDEW PRO I.S. Transmitter is provided with a 5/8"UNF parallel mounting thread which is suitable for installation in an optional flow-through sampling block. The body of the EASIDEW PRO I.S. Transmitter is designed to mate with the bonded seal provided (optional stainless steel bonded Viton seal available). The bonded seal provided should be placed over the 5/8"UNF mounting thread of the EASIDEW PRO I.S. Transmitter before the transmitter is screwed into the sampling block. Assemble into the block by hand first using the wrench flats only. DO NOT grip and twist the Easidew PRO I.S. cover when installing the transmitter. When installed, fully tighten using a wrench until the bonded seal is fully compressed to a torque of 22.5 foot-pounds to 24.0 foot-pounds. The EASIDEW PRO I.S. Transmitter can also be mounted by direct insertion. Remove the protective cap before installation and retain for future use.

If the EASIDEW PRO I.S. Transmitter is to be mounted in the optional sampling block, appropriate gas couplings should be selected and fitted (using PTFE tape) into the female 1/8" NPT (taper) threads provided. Sample gas flow can be in either direction through the block. If the EASIDEW PRO I.S. Transmitter is to be mounted by direct insertion, appropriate care should be taken to insure a proper seal.

Although the operation of the EASIDEW PRO I.S. Transmitter is not sample flow-rate dependent, it is important to insure that the flow velocity through the sample line connecting the sample source to the sample block is high enough to avoid long time lags in response to changes in humidity at the sample source. We therefore recommend a flow rate of 2 to 10 SCFH (1 to 5 liters per minute) at sample point (or equivalent at pressure) be set when the EASIDEW PRO I.S. Transmitter is mounted in the standard sampling block and that the instrument is mounted as close as possible to the sample point. The gas sample may then be returned to the process gas stream via the 2<sup>nd</sup> port in the sample block, or alternatively, if operating conditions allow, the gas sample can be vented. A vent pipe of at least 3 feet in length should be fitted to the outlet port of the sample block. In direct insertion applications a wide range of gas flow velocities are acceptable. Flow velocities up to 30 feet per second (10 meters per second) are acceptable with the protection given by the standard sintered guard.

Note: The correct selection of the cable gland for the EASIDEW PRO I.S. Transmitter is essential with regards to I.S. installations. The specified NEMA 4 rating of the instrument will only be maintained if an equivalent or higher rated ingress protected cable gland is fitted. See EASIDEW PRO I.S. Transmitter specification for dimensions.

After installation into the gas stream, the EASIDEW PRO I.S. Transmitter housing may be positioned at any angle through approximately 330° of rotation, to allow for the cable gland positioning. To position the sensor housing first loosen the large clamping nut sufficient to allow free rotation of the housing around the sensor body.

**WARNING:** The EASIDEW PRO I.S. Transmitter is fitted internally with a stop device to prevent full 360° rotation of the housing around the sensor body. **Rotation beyond 330° may internally damage the sensor.** The stop device is only to provide indication to the installer when maximum travel in either direction has been reached.

Rotate the sensor housing until the cable gland is in the desired position. While firmly holding the housing in position, retighten the large clamp nut up against the housing seal using a wrench of the correct size. Do not apply excessive force.

The Easidew PRO I.S. Transmitter can be supplied with an optional wall-mounting bracket. This allows the customer to support the transmitter physically insuring that the stress on the mounting flange is kept to a minimum. The optional bracket needs to be attached to the Easidew PRO I.S. Transmitter using the hex screws provided. It can be installed either horizontally or vertically and can then be attached to a wall or plate to provide support for the transmitter.

High-pressure samples may be measured up to a maximum of 5000 PSIG. Make sure that the correct pipe fittings are used and that the bonded seal provided is used to seal the radial face of EASIDEW PRO I.S. / sensor block.

Similarly, the EASIDEW PRO I.S. Transmitter is suitable for measuring samples below atmospheric pressure. Care should be taken at joints and pipe fittings that no leak exists which could allow ambient air to contaminate the sample gas. If there is doubt, a standard leak test procedure should be employed (helium or vacuum seal).

Refer to Figure 6 for dimensions of the EASIDEW PRO I.S. Transmitter and optional mounting flange. A brass (or optional stainless steel) ½" NPT conduit/cable gland entry fitting (not shown on the dimensioned drawing) is installed on the Easidew PRO I.S. housing to accommodate conduit or cable entry.

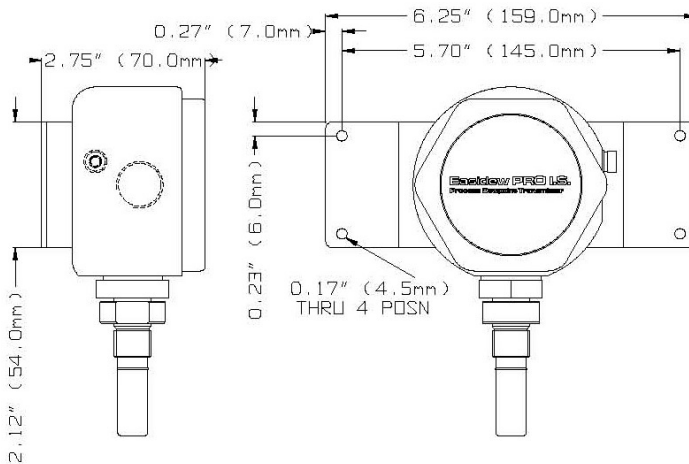
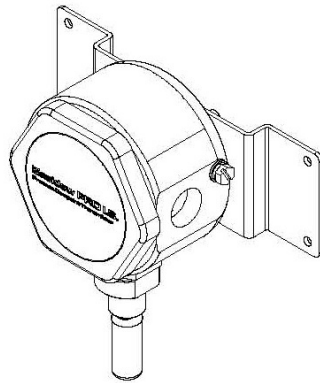
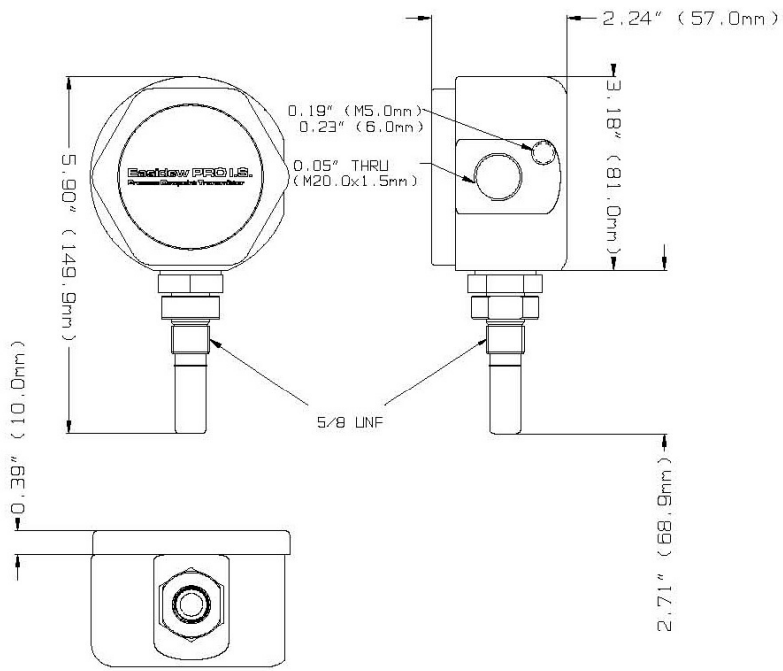

Figure 6. Easidew PRO I.S. Transmitter Dimensions

### 3.3 Operating Precautions

***Precautions should be taken to protect the Kahn Ceramic Moisture Sensor from damage. Statistical information indicates that the vast majority of failures are caused either by incorrect sampling methods, sampling positions or inadequate protection against dangerous substances.***

### 3.4 Sampling Hints

a) Be sure that the sample is representative of the gas under test.

The sample point should be as close to the critical measurement point as possible. For example in a glove box application, mount the EASIDEW PRO I.S. Transmitter at the exit of the glove box, not at the gas entry point. Always use the shortest run of tubing possible between two points.

b) Minimize dead space in sample lines.

Minimize couplings and tubing. Where possible build up sampling tubing specifically for the job and do not use tubing previously installed for another application. Dead space in sample lines increases response time by holding water molecules that are released to the passing gas sample.

c) Remove any particulate matter or oil from the gas sample.

The Ceramic Moisture Sensor element of EASIDEW PRO I.S. Transmitter is protected against particulate contamination by an 80µm stainless steel sintered guard. This protects against physical damage caused by large particles at high velocity, such as rust in a compressed air line. However, fine particles will not be prevented from contact with the Ceramic Sensing Element. If high concentrations of fine particles are present in the sample flow they may "blind" the Ceramic Moisture Sensor element and reduce its response speed. If the EASIDEW PRO I.S. Transmitter is installed in a system where particulate such as degraded desiccant or pipe swarf and rust is present, use a particulate in-line filter. Contact Kahn Technical Support staff for further advice on filtering techniques.

d) Use high quality sample tubing and fittings.

We would recommend that, wherever possible, stainless steel tubing, fittings and components (e.g. filters) be used. This is particularly important when measuring low

dewpoints, since materials other than stainless steel may have undesirable characteristics, such as the adsorbing of moisture on the walls, which slows down response and in extreme circumstances, gives false readings. For temporary applications, or where stainless steel tubing is not feasible, use high quality, thick-walled PTFE (Teflon) tubing as this exhibits similar characteristics to stainless steel.

Use the lowest internal diameter tubing possible to reduce response time, but take care not to induce pressure differentials by aiming for too high a flow rate through small bore tubing. A sampling flow up to 2 to 10 SCFH (1 to 5 liters per minute), or the equivalent at pressure, will be satisfactory for the EASIDEW PRO I.S. Transmitter to operate correctly.

### **3.5 Response Characteristics**

Response characteristics from dry to wet are orders of magnitude faster than from wet to dry. Time taken to dry down the EASIDEW PRO I.S. Transmitter from ambient conditions to the operational dewpoint level of the process will normally be shorter than the time taken to dry down the process itself. Therefore, when the EASIDEW PRO I.S. Transmitter is installed into the system prior to system start-up, there is normally no time lag before representative test results are obtained.

When an EASIDEW PRO I.S. Transmitter is installed into an operational system, then typically fifteen to thirty minutes should be allowed for any tubing, filter and EASIDEW PRO I.S. Transmitter to reach equilibrium with the sample gas passing through.

### **3.6 Which Gases to Measure**

The EASIDEW PRO I.S. Transmitter, by nature of its design, is suitable for measurement of the moisture content of a wide variety of gases. In general, if the gas (in conjunction with water vapor) is not corrosive to base metals then it will be suitable for measurement by the Easidew PRO I.S. Transmitter. However gases containing entrained solids or hydrocarbon mists should be filtered before presentation to the sensor using a coalescing filter. If only particulate matter is present in the sample line then a particulate in-line filter is all that is required. Suitable filters are available from Kahn Instruments.

If a very dry gas, which would become corrosive when coming into contact with higher concentrations of moisture, is to be measured, then the instrument must be purged with an inert gas immediately after the measurement has been made. This will prevent any potentially corrosive gases remaining in the sensor block from contaminating the sensor.

### **3.7 Maintaining the EASIDEW PRO I.S. Transmitter**

Routine maintenance of EASIDEW PRO I.S. should only require regular re-calibrations. The normal calibration period is one year. This re-calibration work can only be performed by exposure of the Moisture Sensor to sample gases of known moisture content. Calibration services traceable to NIST are provided by Kahn Instruments.

The frequency of re-calibrations required to maintain the performance of EASIDEW PRO I.S. Transmitter is primarily dependent on the composition of the gas to which the Moisture Sensor is exposed, i.e. content of liquid and particulate contaminants, corrosive elements, etc. (refer to section 3 of this manual for guidance). In most applications annual re-calibration ensures that the stated accuracy of EASIDEW PRO I.S. is maintained.

## 4. EASIDEW PRO I.S. CABLE CONNECTION

### 4.1 Cable Connection

The cable used for installation can be of any type as long as it meets the intrinsically safe requirements set out by the appropriate standards and EASIDEW PRO I.S. SYSTEM drawing. For the standards, refer to section 4.4. Also, refer to the system drawing at the end of this manual.

Cable connection to the Easidew PRO I.S. is made via the internal terminal block. To gain access to the terminal block, unscrew the lid from the face of the EASIDEW PRO I.S. housing.

### 4.2 Preparation of the Sensor Cable

A prepared 25-foot long sensor cable is included with the Easidew PRO I.S. Hygrometer. When installing the prepared cable, insure that the crimped ferrules are fully inserted into the terminal block before tightening the clamping screw. See illustration in figure 7d on the following page. In the event the user wishes to substitute a longer sensor cable, the procedure illustrated in figures 7a through 7d for preparing the cable must be followed.



**It is essential that, to comply with Hazardous Area Certification of the product, metallic sleeve ferrules must be fitted and crimped onto any cable installed into the connector. Contact Kahn Instruments for information on ferrules to be used.**

**NOTE:** Figures 7a to 7d shown below should be followed in detail. The metallic sleeve ferrules should be applied such that there is no possibility of a conductor strand of a core becoming free.

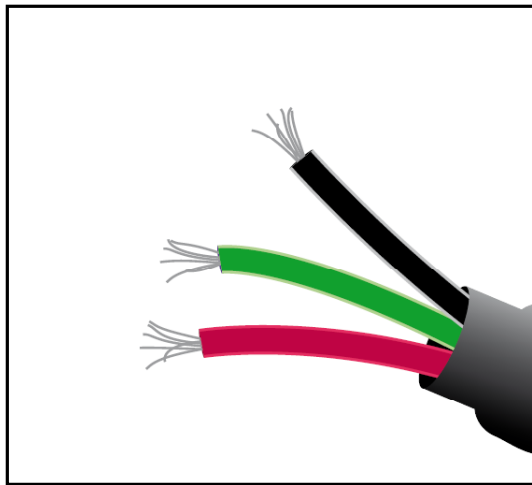

**Figure 7a** Bare Wires

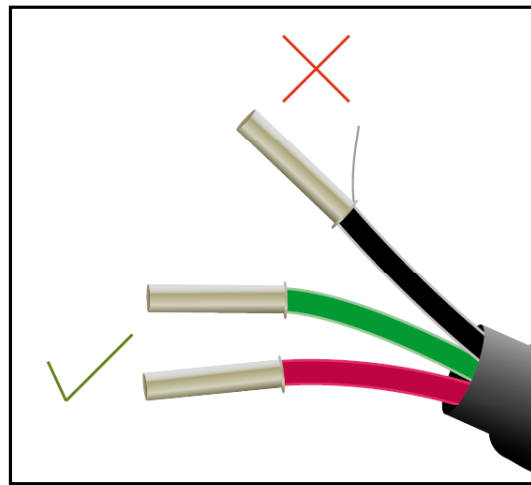

**Figure 7b** Crimped Wires

Note: Actual wire insulation colors may vary

When the crimped ferrule is made it should have a minimum of 2 positions of crimping. After the crimped ferrule is made, it should be trimmed to a length of 0.2 inches (5mm). See figure 7c. When the crimped ferrules are installed into the connector terminal block, insure that they are fully inserted, as shown in Figure 7d, before tightening the terminal clamping screw.

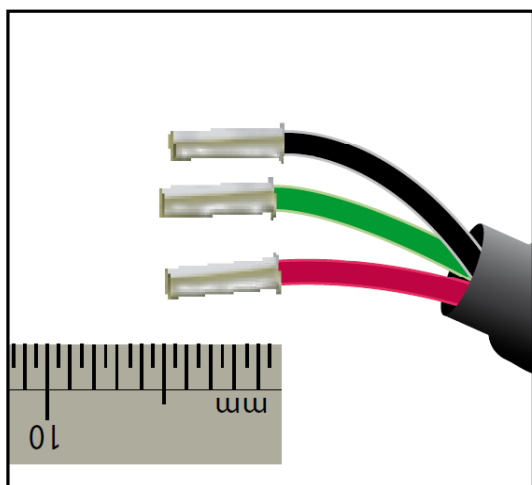

**Figure 7c** Cut to 0.2 Inches (5 mm)

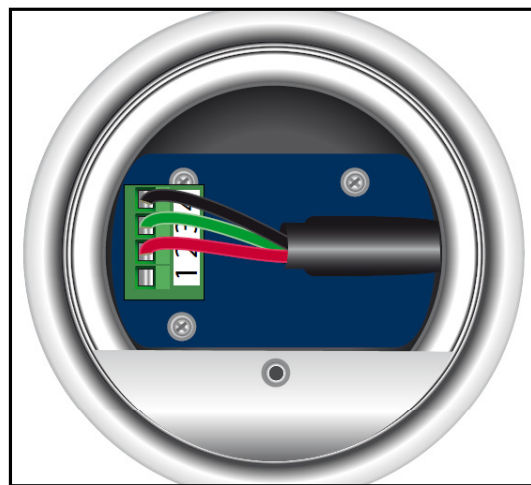

**Figure 7d** Connection to Easidew PRO I.S.

Note: Actual wire insulation colors may vary

When all wire connections are made, insure that there is a minimum clearance distance and a minimum creepage distance in air of 0.08 inches (2.0 mm) between each terminal.

### 4.3 Cable Screen Termination

Any cable used on the installation must be shielded. This shield must always be connected to Ground (Pin 3 of terminal strip) of the EASIDEW PRO I.S. Transmitter. Note: The shield drain wire should not be connected to the Galvanic Isolation Interface.

### 4.4 Installation in Hazardous Areas

The Easidew PRO I.S. Transmitter is certified intrinsically safe for use in hazardous areas, by Notified Body Baseefa 2001 Ltd. The instrument conforms to the ATEX & IECEx standards specified in EN60079-0:2004, EN50020:2002, IEC60079-0:2004 and IEC60079-11:1999 with certification code - Ex II 1 G Ex ia IICT4 Tamb -20°C to +60°C. It is also certified by FM (Certificate number: 3030238) and CSA (Certificate number: 2013218) to Class I, Division 1, Groups A, B, C and D.

Before using the EASIDEW PRO I.S. Transmitter in any hazardous environment, ensure you are fully familiar with the above FM and CSA standards relating to the certification of this instrument and up-to-date codes of practice in the country of installation.

The Easidew PRO I.S. must be installed using the specified GALVANICALLY ISOLATED INTERFACE barrier as shown in the system wiring and isolation barrier installation diagram located on page 35. The Galvanic Isolation Interface and the display monitor must be installed in the non-hazardous (safe) area.

**NOTE: Installation of EASIDEW PRO I.S. Hygrometer MUST be per the system drawing in order to comply with the Intrinsic Safety Certification.**

## **5. CONNECTING EASIDEW PRO I.S. TO THE MONITOR**

The Galvanic Isolation Interface and sensor cable provide the connection between the Easidew PRO I.S. Transmitter and the monitor according to the instrument wiring diagram (Figure 4 on page 12). Refer to section 4 for additional information on cable installation.

## 6. EASIDEW PRO I.S. MONITOR SETUP

There are two levels of operation, USER and ADVANCED.

### User allows:

- Changing of the setpoint values;
- Monitoring of the min/max values.

### Advanced programming allows setting of the following options:

- advanced setpoint programming;
- analog output calibration and scaling;
- auxiliary (optional) channel setup;
- setting the engineering units;
- other related advanced functions.

To access the advanced programming press and release SETUP and  $\uparrow$  simultaneously to scroll through the menus.

### 6.1 Setup Security Feature

To prevent unauthorized access to the internal settings, the monitor is equipped with two DIP-switches located on the display board of the monitor, which can be accessed underneath the faceplate (refer to Figure 8. Location of the LOCKOUT Switches). The PROGRAM LOCKOUT switch SW2 is responsible for enabling or disabling the code programming mode. The SETPOINT LOCKOUT switch SW1 enables or disables the setpoint programming. OFF position of either switch will enable that mode, ON position will disable that mode.

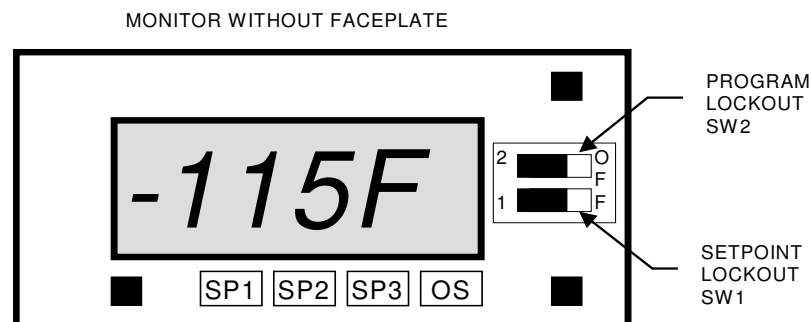

Figure 8. Location of the LOCKOUT Switches

## 6.2 Selecting the Engineering Units

Enter the PROGRAM UNLOCK mode as described in Section 6.1 Setup Security Feature, and press SETUP and  $\uparrow$  to scroll through the menus.

The monitor can display Dewpoint in °C or °F, ppmv, lb/mmscf or g/m<sup>3</sup> (Natural Gas). The selection of these units is achieved by setting CODE 4 and CODE 7 as shown below: (See Appendix 2, CODE 4 & CODE 7 for full details).

To display Dewpoint set CODE 7	to	000
To display Dewpoint in °C set CODE 4	to	200
To display Dewpoint in °F set CODE 4	to	210
To display ppmv set CODE 7	to	100
To display lb/mmscf set CODE 7	to	200
To display g/m <sup>3</sup> set CODE 7	to	300

To set the range and resolution for ppmv, lb/mmscf and g/m<sup>3</sup>, set digit 3 of CODE 7 to :

<b>0</b>	1 – 9999
<b>1</b>	0.1 – 999.9
<b>2</b>	0.01 – 99.99
<b>3</b>	0.001 – 9.999

For example, by setting CODE 7 to 102, the monitor displays ppmv with a resolution of 0.01 to a maximum of 99.99, above which, message oVER will be displayed.

Notice that regardless of the engineering unit selected, pressing the  $\uparrow$  button will switch the display to indicate the dewpoint in degrees C. Pressing the SETUP button will return the display into a previous indication mode.

## 6.3 Changing the Setpoint Values

Before amending the setpoint values, make sure that the monitor is in the SETPOINT UNLOCK mode as described in 7.1 Setup Security Feature.

Press SETUP and  $\downarrow$  simultaneously to gain access to the setpoint codes.

The setpoints of the relays are set by setting **SP<sub>n</sub>** (where n = 1 to 4 and represent SP1 to 4) to the required level. The units of the setpoints change according to the source of the setpoints, i.e. if the indicator is displaying ppmv, then the setpoints are set in ppmv.

For the relays to be energized above the setpoint **SPC<sub>n</sub> = 0xx**.

For the relays to be energized below the setpoint **SPC<sub>n</sub> = 1xx**.

The source of relay setpoints are set by setting digit 2 of **SPC<sub>n</sub>** i.e. **xxn** as shown below:

0	Displayed value ( <b>DEFAULT</b> )
1	Dewpoint

2	Pressure
3	Not applicable for Easidew PRO I.S.
4	Not applicable for Easidew PRO I.S.
5	Not applicable for Easidew PRO I.S.
6	Not applicable for Easidew PRO I.S.

For example, if you wish the relay to trip at a certain dewpoint value while the indicator is displaying ppmv, then **SPC\_n = x1x**.

The secondary relay function is set by digit 3 of **SPC\_n** i.e. **xxn** as shown below:

0	No function <b>(DEFAULT)</b>
1	Relay latched
2	De-energize relay
3	No function
4	Not applicable for Easidew PRO I.S.
5	Not applicable for Easidew PRO I.S.
6	Not applicable for Easidew PRO I.S.
7	Setup for hysteresis, delay type and make/break delay times

For example, if you wish the relay to trip above the setpoint using the displayed value, but to remain latched, then **SPC\_n = 001**. It will then remain latched until the supply to the indicator is removed or **SPC\_n = 002**.

The function of the relay annunciators is set by digit 1 of CODE 1 i.e. **nxX**. As shown below:

0	LED annunciators always OFF
1	LED annunciators ON when relays are de-energized
2	LED annunciators ON when relays are energized <b>(DEFAULT)</b>

### **Hysteresis, Make/Break Delay & Delay Type**

Associated with each setpoint is a Hysteresis Value, Make delay time, Break delay time and a delay type. To gain access to these parameters, set **SPC\_n = xx7** and to scroll the features press  $\uparrow$  or  $\downarrow$ .

The hysteresis value is a value at which the relay trips above and below the nominal setpoint. For example, if SP1 is set to -10.0 and the HYST is set to 2.0 and the relay is set to energize above the setpoint, then the relay will energize when the setpoint source rises above -8.0 and is de-energized when the setpoint source falls below -12.0.

The Make delay is the delay between the setpoint being reached and the relay energizing. For example, if **M\_d = 0.02.30** then the relay will be energized 2 minutes and thirty seconds after the trip point has been reached.

The Break delay is the delay between the relay being energized and it de-energizing. For

example, if **b\_d = 0.01.12** then when the relay is energized it will remain energized for 1 minute and 12 seconds, after which it will be de-energized.

The maximum make and break delay time is 9 hours 6 mins and 6 seconds in increments of 1 second.

The setpoint can have four different delay types: **NorM** (normal), **rEPt** (repeat), **1Shot**, and **PuLSE**.

If **deLAY = NorM** then the relay will function normally with the inclusion of the time delays.

If **deLAY = rEPt** then the make and break delays will repeat continually until the setpoint source goes to a level to deactivate the setpoint. For example, if the make delay = 10 seconds & break delay = 5 seconds, then after the trip point is reached, the relay will energize after 10 seconds and remain energized for 5 seconds after which it will de-energize for 10 sec and then energize for 5 seconds etc.

If **deLAY = PuLSE** then if using the make and break times mentioned above, the relay will energize after 10 seconds, de-energize after 5seconds and remain de-energized.

If **deLAY = 1Shot** then if using the make and break times mentioned above, the relay will energize after 10 seconds and remain energized.

## 6.4 Analog Output Scaling

Enter the PROGRAM UNLOCK mode as described in 7.1, press SETUP then  $\uparrow$ , then SETUP again. Now use  $\uparrow$  and  $\downarrow$  to scroll through to the CAL menu.

The analog output can be scaled by setting CAL to 061 and setting the zero value to the required output at 4mA (or 0V) and the full scale value to the output required at 20mA (or 10V).

For example, if the output is required to go from -90.0°Cdp at 4mA to +10°Cdp at 20mA then set Zero to -90.0 and F.S. to 10.0

To exit the CAL menu, set CAL to 052 and use  $\uparrow$  to scroll through the menus.

## 6.5 Display Brightness Adjustment

To adjust the display brightness:

- press SETUP and ↑ buttons simultaneously, the display toggles between [bri] and [5], where 5 is default setting;
- adjust the display brightness required (from 0 to 7) by using ↑ or ↓ buttons;
- press SETUP several times to exit the programming mode.

## 6.6 Digital Communications

The monitor can be supplied with an optional ASCII RS232 or RS485 serial interface.

The communication settings can be found by setting CAL to 100, then pressing the SETUP button once and then ↑ and ↓ to change the baud rate. Baud rates are 300, 600, 1200, 2400, 4800, 9600, 19,200 and 57.6K. Press the SETUP button again to advance to the parity bit and then ↑ and ↓ to change the parity bit. Parity settings are odd, even or off. Press the SETUP button again to advance to the address settings. Address settings are 0 to 255. Note, address 0 is not a valid RS485 address. Press the SETUP button again to return to CAL.

The communications uses the following default protocol:

Baud rate	9600
Data bits	8
Parity	none
Flow control	Xon/Xoff

The message to read and write to the monitor follows the following format:

- 1) Start Character  
"s" or "S" for the start character (must be first character in string).
- 2) Meter Address  
An ASCII number from "0" to "255" for the meter address. If the character following the start character is not an ASCII number, then address 0 is assumed. All meters respond to address 0.
- 3) Read/Write Command  
The next character must be an ASCII "R" or "r" for read, or an ASCII "W" or "w" for write. Any other character will abort the operation.
- 4) Register Address  
The register address for the read/write operation is specified next. It can be

either an ASCII number from "0" to "255" or registers 1 - 18 can be accessed by entering an ASCII letter from "A" to "R" (or "a" to "r", not case sensitive). If the address character is omitted in a read command, the meter will always respond with the data value currently on the display. (The register address must be specified for a write command).

#### 5) Separator Character

After the register address in a write command, the next character must be something other than an ASCII number. This is used to separate the register address from the data value. It can be a space or a "," or any other character except a "\$" or a "\*".

#### 6) Data Value

After the separator character, the data value is sent. It must be an ASCII number in the range of "-32766" to "32766".

#### 7) Message Terminator

The last character in the message is the message terminator and this must be either a "\$" or a "\*". If the "\$" is used as a terminator, a minimum delay of 50mS is inserted before a reply is sent. If the "\*" is used as a terminator, a minimum delay of 2mS is inserted before a reply is sent. (the "\$" and "\*" characters must not appear anywhere else in the message string).

Examples:

SR\$	Read display value, 50mS delay, all meters respond.
s15r\$	Read display value, 50mS delay, meter address 15 responds.
Sr130*	Read Code 1 setting, 2mS delay, all meters respond.
s2wb-10000\$	Write -10000 to the display register of meter address 2, 50mS delay.
SW65 200\$	Write 200 to the SP1 Hysteresis register, 50mS delay, all meters respond.
s10w148,7*	Change brightness to 7 on meter address 10, 2mS delay.
sr6\$	Reads SP1
sw6-100\$	Sets SP1 to -10.0
sr5\$	Reads pressure value

A full list of the register that can be read or written to can be found in Appendix 1.

## 7. PRESSURE COMPENSATION

Enter the PROGRAM UNLOCK mode as described in 7.1.

The monitor has the ability to provide a pressure compensated value for ppmv, lb/mm<sup>3</sup> or g/m<sup>3</sup>.

### 7.1 Using a Pressure Transmitter

The Easidew PRO I.S. monitor can be supplied with optional dual 4-20 mA input signal conditioner board. One channel is used to measure dewpoint, another channel is used to measure pressure. In order to enable the use of a pressure transmitter, set CODE 4 to 100 (dual channel mode), by pressing SETUP and  $\uparrow$  to scroll through the menus.

If you wish to display Dewpoint while measuring pressure, then set CODE 4 to 100 to show Dewpoint in °C or 110 in °F.

To display pressure in PSIG set CODE 6 to 000, or set CODE 6 to 100 to display in BARG.

#### Manual Pressure Input Calibration

The pressure input channel needs to be calibrated in order to match the range of the pressure transducer. This is achieved by setting CAL to 012 and entering values for offset OFF\_2 and scale SCA\_2.

$$\begin{aligned} \text{SCA\_2} &= 0.0062 \text{ per } 100 \text{ PSIG} \\ \text{OFF\_2} &= \text{pressure range} - ((20,000 \times (\text{pressure range}/1000))/16) \end{aligned}$$

For example, for a pressure transducer with a range of 0 to 1000 PSIG

$$\begin{aligned} \text{SCA\_2} &= 0.0062 \times 10 = 0.0620 \\ \text{OFF\_2} &= 1000 - ((20,000 \times (1000/1000))/16) = 1000 - 1250 = -250 \end{aligned}$$

If you are using a pressure transducer in BARG, then you have to convert the value to PSIG by multiplying it by 14.5.

For a pressure transmitter with a range of 0 to 100 BARG :

$$\begin{aligned} 100 \text{ BARG} &= 1450 \text{ PSIG} \\ \text{SCA\_2} &= 0.0062 \times 14.5 = 0.0899 \\ \text{OFF\_2} &= 1450 - ((20,000 \times (1450/1000))/16) = 1450 - 1813 = -363 \end{aligned}$$

To exit the CAL menu, set CAL to 000 and press  $\uparrow$  to scroll through the menus.

### **Automatic Pressure Input Calibration**

The pressure input can alternatively be calibrated using a 4 and 20mA source. To do this, connect the current source between pin 2 (+) and pin 3 (-).

Set CAL to 022 and press SETUP. The monitor will then display ZERo and flash 0. Set the mA source to 4.0mA and press SETUP to set 0 at 4mA.

Press SETUP and the monitor will display SPAn and flash the full scale pressure value. Set the mA source to 20.0mA and use the  $\uparrow$  &  $\downarrow$  buttons to set the required pressure range. Then press SETUP to set the required pressure for 20.0mA.

Set CAL to 000 and press  $\uparrow$  to leave the menus.

## **7.2 Using a Fixed Pressure Input in Single Channel Mode**

In order to display pressure compensated values of ppmv, lb/mmscf and  $g/m^3$  without the use of a pressure transducer the pressure value must be entered manually.

Enter the PROGRAM UNLOCK mode. Use SETUP and  $\uparrow$  to scroll through the menus and select code 7.

Select the required pressure compensated value, i.e. CODE 7 = 1xx for ppmv, 2xx for lb/mmscf or 3xx for  $g/m^3$ , and CAL = 052.

Exit the menus and exit the PROGRAM UNLOCK MODE. Press SETUP for two seconds, and the display will show the set pressure. To change the pressure, use  $\uparrow$  and  $\downarrow$  and then press SETUP.

## **7.3 Pressure Transmitter Connection**

To maintain the level of intrinsic safety of the system, the optional pressure transmitter must be connected to the monitor using the appropriate Isolation Barrier. Contact Kahn Instruments for details regarding the pressure transmitter installation.

## **8. MONITOR MAINTENANCE**

The EASIDEW PRO I.S. monitor does not require regular re-calibration or servicing. However, if a fault with the monitor is suspected, contact Kahn Instruments technical support.

## 9. TECHNICAL SPECIFICATIONS

### 9.1 EASIDEW PRO I.S. Monitor

<b>Display:</b>	5 digit LED
<b>Dewpoint Measurement Ranges:</b>	-148° F to +68° F, -100° C to +20° C, 0 to 9999 ppmv; 0 to 1000 lb/mmscf, g/m <sup>3</sup> (Natural Gas).
<b>Pressure input channel: (Optional)</b>	4-20 mA input scaleable to any engineering units.
<b>Electronic accuracy:</b>	PPMV range ±1% of reading, LB/MMSCF range ±1% of reading, secondary channel ±0.5% FS.
<b>Outputs:</b>	Isolated 4-20mA as standard (max load 500 ohms) or 0-10V optional (min load 5 kOhms), spanned to full calibration range, scaleable by user.
<b>Alarm Relays:</b>	Two relays SP1 and SP2 are standard. Control action and setpoints are user programmable. Form C contacts rated 10 A, 240 VAC or 8 A 24 VDC non-inductive load.  Relays SP3 and SP4 (OS) are optional. Control action and setpoints are user programmable. Form A contacts rated 5 A, 240 VAC or 5 A, 30 VDC non-inductive load.
<b>Operating environment:</b>	+32° to +122° F (0° to +50° C), 0 to 90%RH.
<b>Power supply:</b>	85-265 VAC, 50/60 Hz standard. Optionally: 18-36 VAC or 9-60VDC.
<b>Power consumption:</b>	Max 10 Watts.
<b>Power connection:</b>	6 feet, 3-wire.
<b>Weight:</b>	1.32 lbs.
<b>Environmental protection:</b>	IP54 / NEMA 12. Optional protection cover to IP66 / NEMA 4.

## 9.2 EASIDEW PRO I.S. Transmitter

### Intrinsic Safety Certification (With Safety Barrier)

FM approval  
CSA approval

Class I, Division 1, Groups A, B, C & D T4 (Certificate 3030238)  
Class I, Division 1, Groups A, B, C & D T4 (Certificate 2013218)

Sensor type  
Output signal

Kahn Ceramic Moisture Sensor  
4 to 20 mA linear current source output (2-wire, loop powered)  
corresponding to °F or °C dewpoint range

Range

-148°F to +68°F (-100°C to +20°C) dewpoint  
0 to 3000 PPMv

Accuracy

±3.6°F (±2°C) dewpoint

Electrical connection  
Supply voltage

½" NPT conduit/cable gland entry fitting; screw terminals  
12 to 28 V

Sensor mounting thread  
Housing

5/8"-18 UNF  
Heaving duty process type; 316 stainless steel, polished finish

Ingress protection  
Sensing element filter

NEMA 4, IP66  
80µ stainless steel sintered guard (10µ HDPE guard optional)

Current consumption  
Repeatability

20 mA  
1.0°F dewpoint

Operating temperature  
Temperature coefficient

-40°F to +140°F (-40°C to +60°C)  
Temperature compensated across operating temperature range

Operating pressure  
Storage temperature

Max. 5000 PSIG (300 Barg)  
-40°F to +158°F (-40°C to +70°C)

Flow rate  
Gas Velocity

2-10 standard cubic feet per hour (1 to 5 normal liters per minute)  
0 to 30 feet per second direct insertion

Interchangeability  
Load resistance

Fully interchangeable transmitters  
Maximum 250 ohms at 12 volts  
500 ohms at 24 volts

Dimensions  
Weight

Outline: 5.9" high x 4.0" wide x 2.24" deep  
2.9 lbs. (1.3Kg)

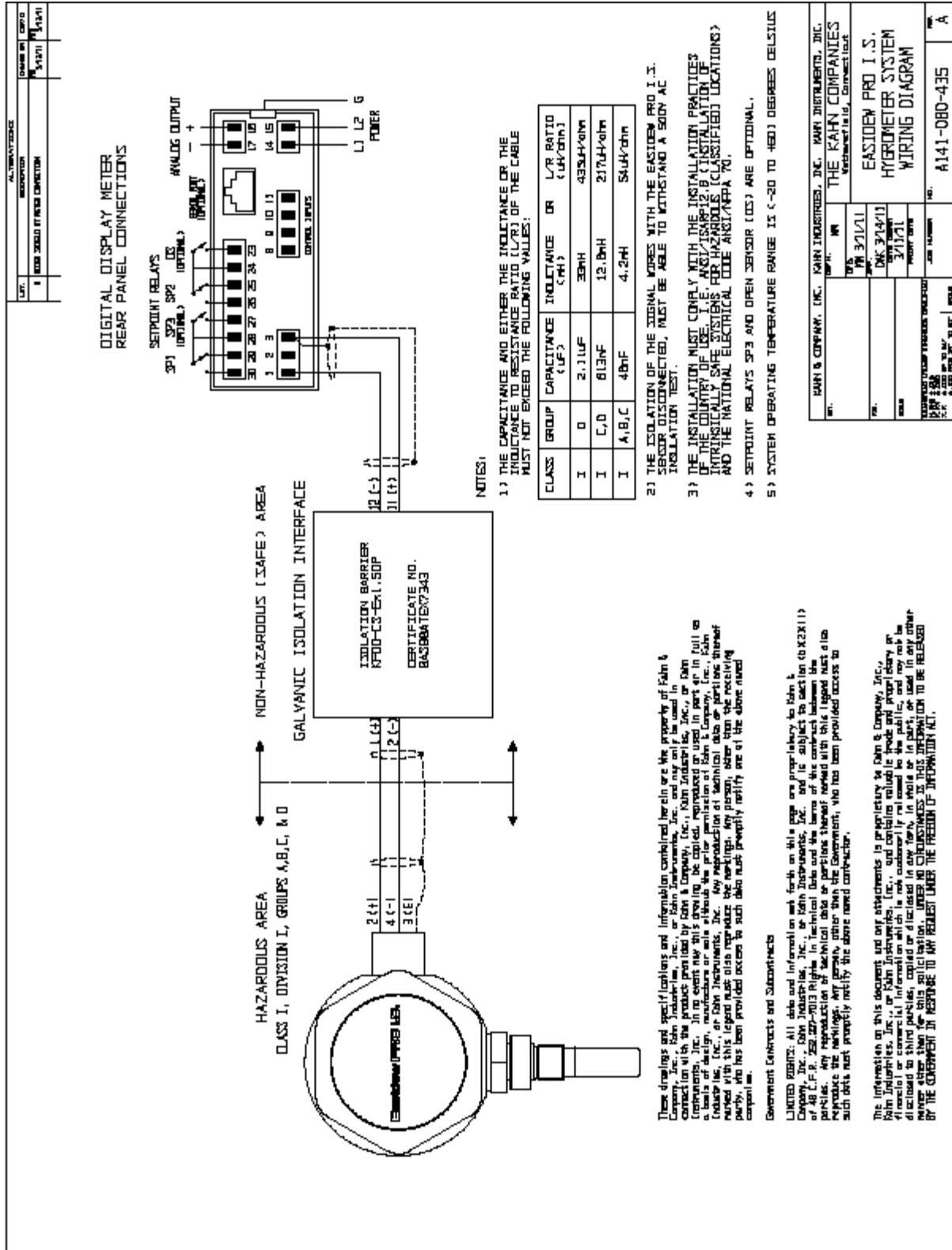

Figure 9. System Wiring and Isolation Barrier Installation

## ATTACHMENT 1

## Register Settings Accessible by Digital Communication

Register number	Function	Read only
1	Alarm Status	
2	N/A	
3	Processed Data – Result	✓
4	Processed Data – Channel 1 (dewpoint)	✓
5	Processed Data – Channel 2 (pressure)	✓
6	Setpoint 1	
7	Setpoint 2	
8	Setpoint 3	
9	Setpoint 4	
10 to 23	N/A	
24	Scale Value – Result	
25	Scale Value – Channel 1	
26	Scale Value – Channel 2	
27	Offset Value – Result	
28	Offset Value – Channel 1	
29	Offset Value – Channel 2	
30 to 33	N/A	
34	D/A Zero – Analogue O/P 1	
35	N/A	
36	D/A Full Scale – Analogue O/P 1	
37 to 64	N/A	
65	Hysteresis - Setpoint 1	
66	Hysteresis - Setpoint 2	
67	Hysteresis - Setpoint 3	
68	Hysteresis - Setpoint 4	
69 to 70	N/A	
71	Make Delay - Setpoint 1	
72	Make Delay - Setpoint 2	
73	Make Delay - Setpoint 3	
74	Make Delay - Setpoint 4	
75 to 76	N/A	
77	Break Delay - Setpoint 1	
78	Break Delay - Setpoint 2	
79	Break Delay - Setpoint 3	
80	Break Delay - Setpoint 4	
81 to 128	N/A	
129	Cal Mode	
130	Code 1	

131	Code 2
132	Code 3
133	Code 4
134	Code 5
135	Code 6

### Register Settings Accessible by Digital Communication cont.

Register number	Function	Read only
136	Code 7	
136	Code 8	
138	to 141	Reserved
142	Setpoint 1 Control Register	
143	Setpoint 2 Control Register	
144	Setpoint 3 Control Register	
145	Setpoint 4 Control Register	
146 to 147	N/A	
148	Brightness	
149	Baud rate Settings	
150	Serial Address	
151 to 152	N/A	
153	Model Number	✓
154	Version Number	✓
155 to 192	N/A	
193	Delay Type – Setpoint 1	
194	Delay Type – Setpoint 2	
195	Delay Type – Setpoint 3	
196	Delay Type – Setpoint 4	

## ATTACHMENT 2

## Setup Codes

**CAL** (Calibration modes for input and output.)

1<sup>st</sup> digit (left most): Calibration mode

<b>Digit:</b>	<b>Function</b>
0	Calibration functions as per 2 <sup>nd</sup> and 3 <sup>rd</sup> digit
1	Set baud rate, parity and serial address

2<sup>nd</sup> digit: Calibration function

<b>Digit:</b>	<b>Function</b>
0	No function
1	Manual calibration (channel as per 3 <sup>rd</sup> digit)
2 to 4	N/A
5	Manual adjust
6	Analog output scaling (analogue channel as per 3 <sup>rd</sup> digit)
7	Analog output calibration

3<sup>rd</sup> digit: Object for calibration

<b>Digit:</b>	<b>Function</b>
0	No function
1	Processed result (dewpoint, ppmv, lb/mmscf, g/m <sup>3</sup> )
2	Pressure input

**DEFAULT VALUE = 052**

**CODE 1** (Tendency Indication, Additional LED's, Display data source, Display flashing, Decimal points, Display rounding)1<sup>st</sup> digit (left most): additional LED's

<b>Digit:</b>	<b>Function</b>
0	LED annunciators are always off
1	LED annunciators are on when relays are de-energized
2	LED annunciators are on when relays are energized
3	N/A

2<sup>nd</sup> digit: Display data source

<b>Digit:</b>	<b>Function</b>
0	Processed data - result (dewpoint, ppmv, lb/mm scf, g/m <sup>3</sup> )
1	Processed data - channel 1 (dewpoint only)
2	Processed data - pressure
3 to 7	N/A

3<sup>rd</sup> digit: 0 only**DEFAULT VALUE = 200****CODE 2** (Totalizer functions & calibration of linearization tables)

Access denied.

**DEFAULT VALUE = 000****CODE 3** (Serial mode and analog output source)

Access denied.

**DEFAULT VALUE = 000****CODE 4** (Channel 1, Measurement task, sampling rate)1<sup>st</sup> digit (left most): Analog sample rate

<b>Digit:</b>	<b>Function</b>
0	Single channel (60Hz)
1	Dual channel (60Hz)
2	Single channel (50Hz)
3	Dual channel (50Hz)

2<sup>nd</sup> digit: Analog output 1 source

<b>Digit:</b>	<b>Function</b>
0	Dewpoint in degrees C
1	Dewpoint in degrees F

3<sup>rd</sup> digit: 0 only

**DEFAULT VALUE = 010**

**CODE 5** (Channel 1 Processing)

**DEFAULT VALUE = 100**

**CODE 6** ( Channel 2, Measurement task)

1<sup>st</sup> digit (left most): Measurement task

<b>Digit:</b>	<b>Function</b>
0	Pressure in PSIG
1	Pressure in BARG
2	N/A

2<sup>nd</sup> digit: 0 only

3<sup>rd</sup> digit: 0 only

**DEFAULT VALUE = 000**

**CODE 7** (Result processing)

1<sup>st</sup> digit (left most): Measurement task

<b>Digit:</b>	<b>Function</b>
0	Dewpoint
1	ppmv
2	lb/mmscf (Natural Gas)
3	g/m <sup>3</sup> (Natural Gas)

2<sup>nd</sup> digit: 0 only

3<sup>rd</sup> digit: Range for result

<b>Digit:</b>	<b>Function</b>
0	1 – 9999
1	0.1 – 999.9

2	0.01 – 99.99
3	0.001 – 9.999

**DEFAULT VALUE = 000**

**CODE 8 (Data logging and print mode options)**

Access denied.

**DEFAULT VALUE = 000**

**SPC (Setpoint control 1 – 6, accessed from SETUP/Down menu after setpoints)**

**Relay latching, relay setup, source**

1<sup>st</sup> digit (left most): Relay sense

<b>Digit:</b>	<b>Function</b>
0	Relay energized above setpoint value
1	Relay energized below setpoint value
2 to 3	N/A

2<sup>nd</sup> digit: Setpoint source

<b>Digit:</b>	<b>Function</b>
0	Processed result data (dewpoint, ppmv, lb/mm <sup>3</sup> scf, g/m <sup>3</sup> )
1	Dewpoint only
2	Pressure
3	Not applicable for Easidew PRO I.S.
4	Not applicable for Easidew PRO I.S.
5	Not applicable for Easidew PRO I.S.
6	Not applicable for Easidew PRO I.S.

3<sup>rd</sup> digit: Setpoint function for SP1 – SP4

<b>Digit:</b>	<b>Function</b>
0	No function
1	Relay latched
2	De-energized relay
3	N/A
4	Not applicable for Easidew PRO I.S.
5	Not applicable for Easidew PRO I.S.
6	Not applicable for Easidew PRO I.S.
7	Setup hysteresis, make/break delay and delay type

**DEFAULT VALUE = 000**

## ATTACHMENT 3

**Error Messages**

The table below represents the possible error messages that can be seen on the hygrometer monitor under different conditions.

<b>Error message</b>	<b>Possible cause</b>	<b>Action</b>
Under	1. Measured dewpoint is below the measurement range (-100 °C/-148 °F)	Contact Kahn Instruments regarding your application
	2. Sensor is out of calibration or damaged	Contact Kahn Instruments for sensor repair or recalibration
Over	1. Measured dewpoint is above the measurement range (+20 °C/+68 °F)	Contact Kahn Instruments regarding your application
	2. Sensor was in contact with liquid water	Dry the sensor out with a stream of dry gas
	3. Sensor is out of calibration or damaged	Contact Kahn Instruments for sensor repair or recalibration
	4. Sensor is contaminated	Contact Kahn Instruments for sensor repair and application assistance
Open	1. Bad electrical connection between sensor and monitor	Verify connectivity of the sensor cable
	2. Internal sensor failure	Contact Kahn Instruments for sensor repair
	3. Internal monitor failure	Contact Kahn Instruments for monitor repair
ErrE	Internal monitor temporary memory corruption due to unusually high power voltage spike	Perform the following monitor resetting procedure: 1. Turn the power OFF. 2. Press and hold the ↑ and ↓ buttons. 3. Turn the power ON 4. Release the ↑ and ↓ buttons. 5. Verify the monitor settings (alarm setpoints, output scaling, etc.)