

Easidew On-line Hygrometer

Users Guide



March 2007

Manual No.97094

12 Pages

KAHN INSTRUMENTS, INC.

885 Wells Road, Wethersfield, CT, USA
Phone: (860) 529-8643 Fax: (860) 529-1895
Web Site: www.kahn.com
E-mail: info@kahn.com

TABLE OF CONTENTS

<u>SECTION</u>	<u>PAGE</u>
INTRODUCTION	
1. PREPARATION	3
1.1 Installing the Monitor	3
1.2 Electrical Power	5
1.3 Sensor Cable Connections	5
1.4 Reviewing/Changing Alarm Settings	6
1.5 Changing Alarm Settings to Above or Below Setpoint.	6
1.6 4-20 / 0-20 mA Output.	7
1.7 Installing the Sensor.	7
2. OPERATION	8
2.1 Sampling Hints	8
2.2 Which Gases to Measure?	8
3. MODBUS RTU COMMUNICATIONS	9
4. MAINTENANCE	9
APPENDIX 1 TECHNICAL SPECIFICATIONS	10
APPENDIX 2 ALTERNATIVE RANGES	11

INTRODUCTION

The Easidew On-line Hygrometer is a continuous, on-line instrument for the measurement of moisture content in a gas over an operating range of -100°C to $+20^{\circ}\text{C}$ / -148°F to $+68^{\circ}\text{F}$ dew point. A 4-20/0-20 mA current output is provided, along with a dual alarm output (a third alarm output is optional).

Our calibration facilities are among the most sophisticated in the world and are traceable directly to the National Institute of Standards and Technology (**NIST**) over the range -75 to $+20^{\circ}\text{C}$ dew point. Our full range calibration facility extends from -100 to $+90^{\circ}\text{C}$ dew point.

1. PREPARATION

On delivery, please check that all the following standard components are present in the packing box:

- | | | |
|----------------|-------------------|--------------------------|
| 1) Monitor | 2) Easidew Sensor | 3) Sensor cable assembly |
| 4) Sensor seal | 5) Power cable | |
| 7) Screwdriver | | |

1.1 Installing the Monitor

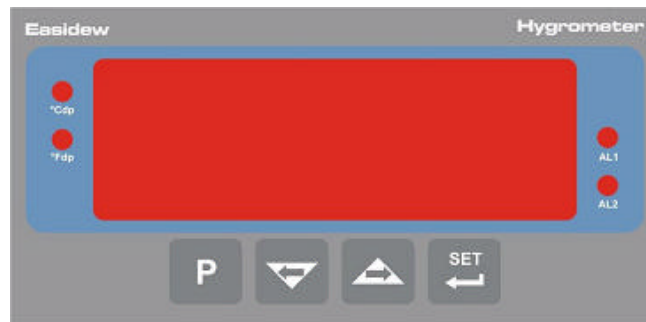

The monitor requires an operating environment of 0°C to 50°C / $+32^{\circ}\text{F}$ to 122°F , 0-90 %RH (non-condensing). The monitor case is designed for panel mounting and is inserted from the front and secured using the two brackets provided.

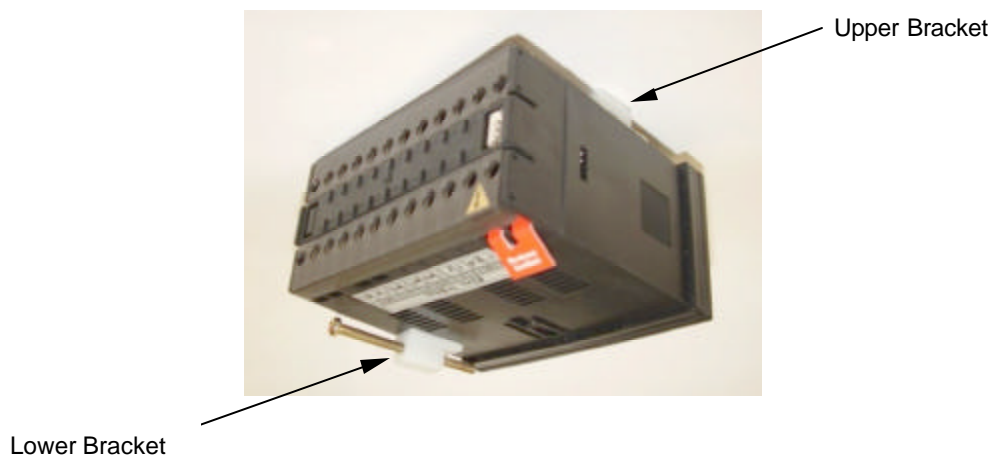

For panel mounting, a suitable DIN 1/8 cutout (3.62" x 1.77"; 92mm x 45mm) is required.

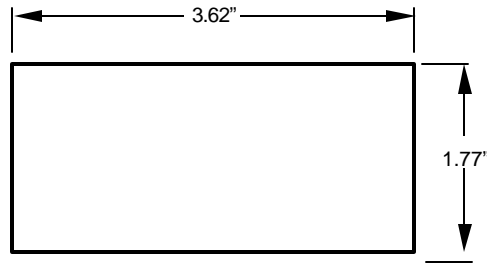

A minimum depth behind the panel of 3.15" (80mm) is recommended (see Figure 1. Case Dimensions). However, the monitor can be used as a bench mounted device without any special preparation.

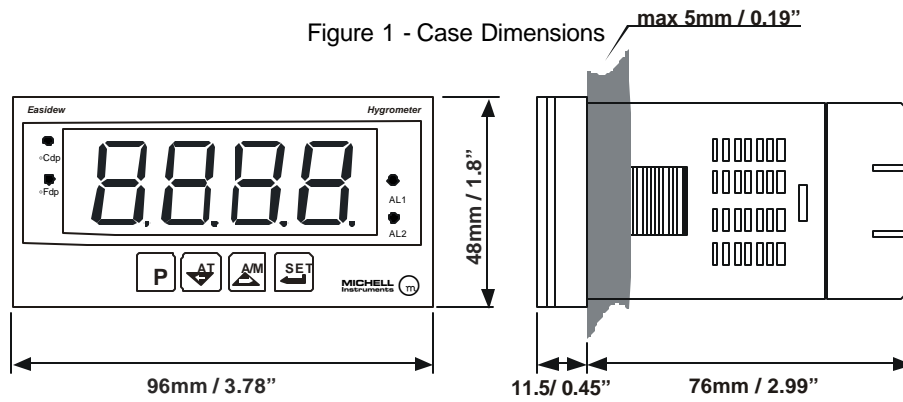

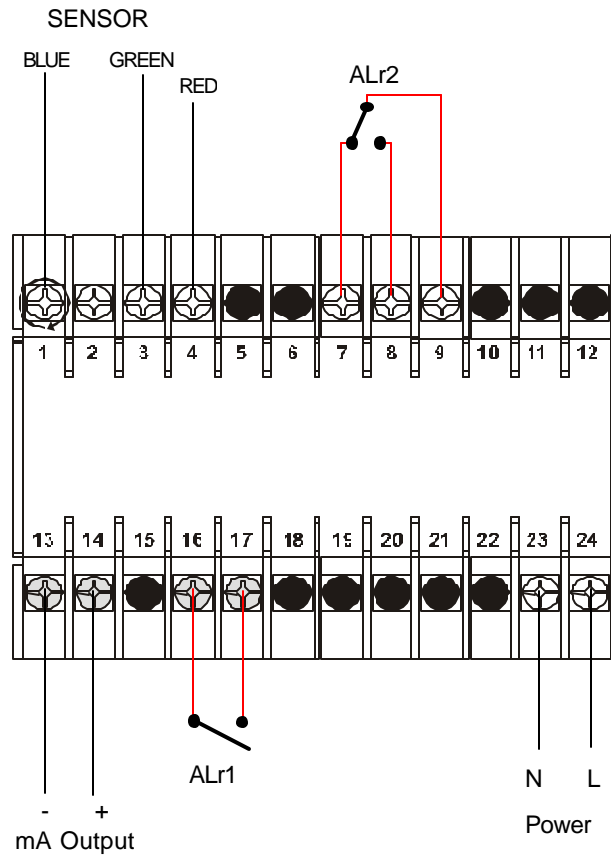

Figure 2 - Monitor Connections.

1.2 Electrical Power

The power supply to the monitor is factory set to 85-264V AC, 50/60 Hz.
 The connections are: Live (L) pin 24, Neutral (N) pin 23.

Optional supply voltage is factory set to 24V DC

The connections are: (+) pin 24, (-) pin 23.

1.3 Sensor Cable Connections

The sensor cable should be connected to the monitor by its three terminated wires as shown in the following table. The sensor connector terminations are shown for reference (supplied pre-wired).

Function	Power (+16 V nominal)	4-20 mA (Source)	Ground
	Red Wire	Green Wire	Blue Wire & Shield
Monitor	Pin 4	Pin 3	Pin 1
Sensor Connector (Pre-wired)	Pin 3	Pin 1	Pin (GND)

The standard cable length is 6 feet. Longer cable lengths can be supplied on request from Kahn Instruments. Alternatively, users can provide their own cable but must insure that it meets the requirements listed under Technical Specifications. See Appendix 1.

1.4 Reviewing/Changing Alarm Settings



Figure 3 - Monitor Settings.

Alarm set-point values are referred to as ALr1 and ALr2 in the menu. To access the relevant alarm set-point, press the SET button once for ALr1 and twice for ALr2.

To adjust the set-point press one of the ARROW buttons. The display will now flash the current set-point. Use the ARROW buttons to adjust to the required value.

Press the SET button and the new value will be saved. Pressing the P button will exit the alarm setting mode without saving the new value.

Error Messages.

ErrL = Open circuit, Sensor disconnected.

ErrH = Over Range.

1.5 Changing Alarm Settings to Above or Below Setpoint.

Press and hold the P button and the display should read 'tECH'. Press the SET button and the display should flash between 'PinP' and 'ConF'.

Press the RIGHT ARROW button 2 times until the display flashes between 'ALr 1' and 'ConF'.

Press the SET button 2 times and the display should read 'ALt 1'. Press the RIGHT ARROW button to reveal a flashing value on the display. Using the ARROW buttons adjust the flashing value to '0000' to alarm above the setpoint or '0001' to alarm below the setpoint.

Press the SET button and the display should read 'ALH 1'. Press the SET button 3 more times until the display flashes between 'ALr 1' and 'ConF'.

Press the RIGHT ARROW button to show 'ALr 2'.

Press the SET button 2 times and the display should read 'ALt 2'. Press the RIGHT ARROW button to reveal a flashing value on the display. Using the ARROW buttons adjust the flashing value to '0000' to alarm above the setpoint or '0001' to alarm below the setpoint.

Press the SET button 4 times followed by the P button to get back to the normal display.

1.6 4-20 / 0-20 mA Output.

The 4-20 / 0-20 mA linear output signal is available on the rear panel of the instrument (pins 13 & 14) and is ranged over -100°C to $+20^{\circ}\text{C}$ / -148°F to $+68^{\circ}\text{F}$ dewpoint. The Max load resistance is 500 ohms.

1.7 Installing the Sensor.

Remove the plastic protective cap from sensor before installation and retain for future use. The sensor has a 5/8"-18 UNF mounting thread and can be mounted either in an optional flow-through sensor sampling block or directly inserted to a pipe or duct. The bonded seal provided is designed for operation at pressures up to 5000 PSIG when the sensor is fitted using the 5/8" -18 UNF mounting thread and should be placed over the sensor before it is screwed into the sampling location. Fully tighten to a **minimum torque of 30.5Nm/22.5ft-lbs.**

When connected to a stainless steel tubing system, the sensor and sampling block need no additional support. However, if PTFE tubing is used, it may be necessary to secure the sampling block using a suitable spring clip or clamp. Kahn recommends a gas flow rate of 1 to 5 liters/minute (2-10 SCFH) when the sensor is mounted in the standard sampling block. For direct insertion applications, gas flow can be from static to 10 meters/second (32 ft/second).

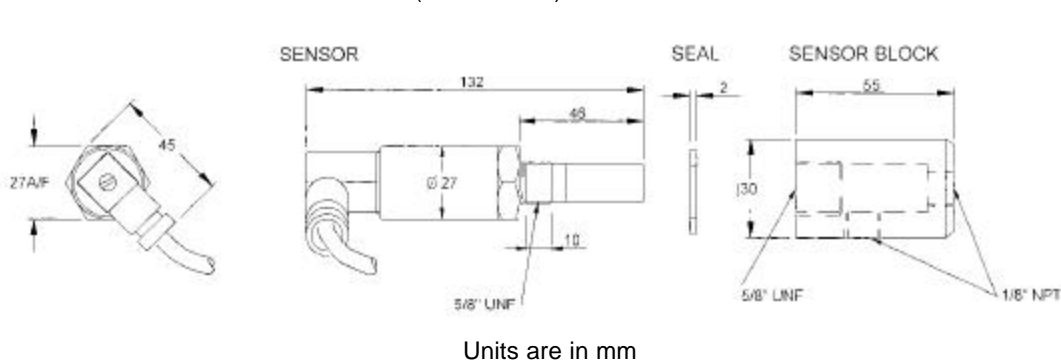

2. OPERATION

Operation of the Easidew On-line Hygrometer is very simple assuming that sensible precautions are taken to protect the sensor from damage.

1.8 Sampling Hints

Be Sure the Sample is Representative of the Gas Under Test: The sample point should be as close to the critical measurement point as possible. Also, never sample from the bottom of a pipe – entrained liquids may be drawn into the sensor.

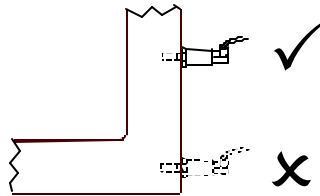

Minimize Dead Space in Sample Lines: Dead space in sample lines causes moisture entrapment points, increased system response times or measurement errors as the trapped moisture is released into passing sample gas, causing an increase in partial vapor pressure.

Remove Any Particulate Matter or Oil from the Gas Sample: Particulate matter at high velocity can damage the sensor. Similarly, at low velocity, they may "blind" the sensor and reduce its response speed. If particulate, such as degraded desiccant or pipe rust is likely to be present in the sample gas, use a particulate in-line filter. Kahn Instruments technical sales will be pleased to provide advice.

Use High Quality Sample Tubing and Fittings: We recommend that wherever possible, stainless steel tubing and fittings be used. This is particularly important at low dew points since other materials have hygroscopic characteristics and adsorb moisture on the tube walls, slowing down response and, in extreme circumstances, giving false readings. For temporary applications, or where stainless steel tubing is not practical, use high quality thick-walled PTFE tubing.

1.9 Which Gases to Measure?

The Easidew On-line Hygrometer is suitable for measurement of the moisture content of a wide variety of gases. In general, if the gas (in conjunction with water vapor) is not corrosive to ceramics or base metals, then it will be suitable for measurement by the Easidew On-line Hygrometer.

2. MODBUS RTU COMMUNICATIONS

Implemented within the Easidew monitor is MODBUS RTU communications via RS232. This protocol offers two-way communication between a P.C. or PLC known as the master to the monitor known as a slave, enabling read/write access to the monitor's configurations and parameters.

Connection diagram:

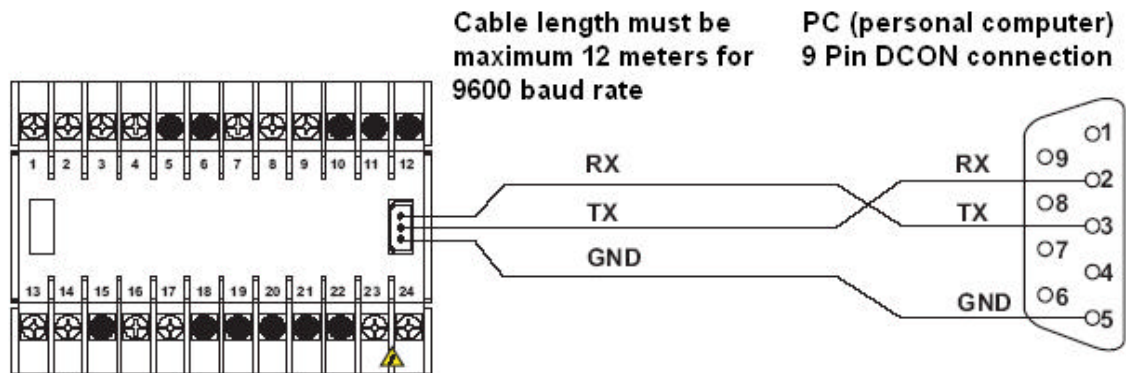

Figure 4 - Transmission specifications:

Interface:	RS-232
Communication System:	Half Duplex
Data Length :	8 bits
Parity:	None, odd, even
Stop Bit	1, 2 stop bits
Transmission Rate:	1200, 2400, 4800, 9600 and 19200

For more information on the MODBUS RTU COMMUNICATIONS, please contact Kahn Instruments.

3. MAINTENANCE

Routine maintenance of the Easidew On-line Hygrometer is confined to regular re-calibrations of the Easidew sensor. In most cases, annual re-calibration insures that the stated accuracy of the Easidew On-Line Hygrometer is maintained.

A true calibration can only be performed by exposure of the moisture sensor to a reference gas of known dewpoint.

Calibration services are offered by Kahn Instruments. All calibrations are traceable to the National Institute of Standards and Technology (NIST).

The Easidew can be returned to Kahn Instruments, either directly or via the authorized representatives, for calibration at 13 points across the range -100°C to +20°C/-148°F to +68°F dewpoint.

Easidew sensors are fully interchangeable and can be used with any Easidew On-Line Monitor. In addition, this interchangeability is not affected by sensor cable length.

APPENDIX 1 TECHNICAL SPECIFICATIONS**Monitor:****Equipment use:**

Housing & Mounting:

Protection:

Weight:

Environmental rating:

Operating temperature:

Storage temperature

Operating / Storage humidity:

Mode of operation:

Supply voltage:

Alr1 Relay:

Alr2 Relay:

Alr3 Relay:

Analog Output:

Process Display :

LED indicators:

Power connection:

Sensor cable:

Process indicator equipment

3.78"W 1.8"H x 2.99"D (96mm W x 48mm H x 86mm D)

Plastic housing for panel mounting.

Panel cut out is 3.62"W x 1.77"H (92mm W x 45mm H)

NEMA 12 (IP65 at front, IP20 at rear).

Approximately 0.5 lbs. (0.21 Kg.)

Standard, indoor at an altitude of less than 6500 feet
(2000 meters) with non condensing humidity

23°F to +131°F (-5°C to -55°C)

-40°F to +185°F (-40°C to +85°C)

90 % max. (non condensing)

Continuous

85 to 264 VAC 50/60 Hz. (Optional 24V DC).

3A@250Vac

5A@250Vac

Optional, consult factory

4-20mA (or 0-20mA) over the range -148°F to +68°F
(-100°C to +20°C)

20 mm Red 4 digit LED display

AL1, AL2, °C, °F

2 meter, 2 wire.

Copper braid shielded cable; 4 core 7/0.2 (0.22mm²),
stranded, tinned copper conductors, PVC, insulated, Melinex
taped, Black PVC outer.

Max length 2600 feet.

Sensor:

Type:

Kahn Easidew.

Sensor Torque Loading:

Minimum 22.5 ft-lbs (30.5Nm)

Calibration range:

-148°F to +68°F (-100°C to +20 °C) dew point.

Output:

4-20 mA current source over the entire dew-point range

Interchangeability:

Fully interchangeable sensors.

Dewpoint accuracy:

±3.6°F (±2.0°C)

Gas temperature:

-40°F to +140°F (-40°C to +60 °C)

Operating environment:

68°F to 122°F (20°C to +50 °C)

Storage temperature:

-40°F to +167°F (-40°C to +75 °C)

Temperature coefficients:

Temperature compensated.

Operating pressure:

10⁻⁶ Bara vacuum to 5000 PSIG.

Flow rate:

2 to 10 SCFH (1 to 5 liters/minute) mounted in standard sampling block
0 to 30 feet/second (0 to 10 meters/second) direct insertion (80µm
sintered guard)

Traceable certification:

-75 to +20 °C dew point traceable to **NIST**[For dew points < -90 °C: Direct reference to a fundamental cooled
mirror dew point meter]

Environmental protection:

NEMA 12/IP65 (Optional NEMA 4 or IP66)

Weight:

0.33 lbs (0.15 Kg)

APPENDIX 2 ALTERNATIVE RANGES

The Easidew monitor can be re-ranged to match the range of the Easidew transmitter.

Ranging of the monitor is achieved by using the following procedure.

- 1) Press P button and the display will show "tECH".
- 2) Press the SET button until the display shows "tPoL". Press any Arrow button. The display will now show the current "minimum calibration value". Use the ARROW buttons to adjust the value to the minimum range value.
- 3) Press the SET button until the display shows "tPoH". Press any Arrow button. The display will now show the current "maximum calibration value". Use the ARROW buttons to adjust the value to the maximum range value.
- 4) Press the SET button until the display shows "LoL". Press any Arrow button. The display will now show the current "minimum display value". Use the ARROW buttons to adjust the value to the minimum range value.
- 5) Press the SET button until the display shows "uPL". Press any Arrow button. The display will now show the current "maximum display value". Use the ARROW buttons to adjust the value to the maximum range value.
- 6) Press the SET button.
- 7) Press the P button twice to return to the dewpoint display.

Re-ranging the Easidew transmitter requires the use of a Communications Kit and Easidew Transmitter Application Software. The Communications Kit and Application Software are available in two versions, dependant upon the product code of the transmitter shown on the serial number label. Contact Kahn Instruments Customer Service Department for details.