

**CERMET II HYGROMETER**  
**INSTALLATION, OPERATION AND**  
**MAINTENANCE MANUAL**

Issue May 2003

---

**KAHN INSTRUMENTS, INC.**

885 Wells Road, Wethersfield, CT 06109  
Tel: 860-529-8643; Fax: 860-529-1895  
E-mail: [info@kahn.com](mailto:info@kahn.com)  
[www.kahn.com](http://www.kahn.com)

## Table of Contents

1.	INTRODUCTION	4
1.1	General	4
1.2	Cermet II Hygrometer	4
1.3	Ceramic Technology Sensor	4
1.4	Calibration	4
1.5	Manufacturing Quality	5
2.	PREPARATION	6
2.1	Installing the Monitor	6
2.2	Electrical Connections	7
2.2.1	<b>Electrical Power</b>	8
2.2.2	<b>Setpoint (Alarm) Relays</b>	8
2.2.3	<b>Analog Output</b>	8
2.2.4	<b>Digital Interface</b>	8
2.3	Sensor Cable	9
2.4	Dewpoint Sensor Installation	9
3.	INSTRUMENT SETUP	10
3.1	Setup Security Feature	10
3.2	Selecting the Engineering Units	11
3.3	Changing the Setpoint Values	11
3.4	Analog Output Scaling	13
3.5	Display Brightness Adjustment	14
3.6	Digital Communications	14
4.	PRESSURE COMPENSATION	16
4.1	Using an Optional Pressure Transducer	16
4.2	Using a Fixed Pressure Input in Single Channel Mode	17
4.3	Optional Pressure Transducer Connection	17
5.	OPERATION	19
5.1	Sampling Hints	19
5.2	Response Characteristic	20
5.3	Which Gases to Measure?	20
6.	TECHNICAL SPECIFICATIONS	22
6.1	Monitor	22
6.2	Sensor	23
7.	MAINTENANCE	24

APPENDIX 1	25
<b>Register settings accessible by digital communication</b>	25
APPENDIX 2	27
<b>Setup Codes</b>	27
APPENDIX 3	32
<b>Error Messages</b>	32

# 1. INTRODUCTION

## 1.1 General

Kahn Instruments manufactures and distributes a wide range of on-line and portable instruments for the determination of moisture content in air and gases. In addition, the company manufactures humidity calibration systems for industrial and scientific users.

## 1.2 Cermet II Hygrometer

The Cermet II hygrometer is a continuous, on-line instrument for the measurement of absolute moisture content in gas. It is designed to operate under a wide range of conditions and provide for the monitoring and/or control of moisture in gases. The instrument consists of two component parts: monitor and sensor, each of which is individually calibrated to a single standard allowing combinations of sensor and monitor units to be totally interchangeable.

The standard instrument covers the ranges  $-100^{\circ}\text{C}$  to  $+20^{\circ}\text{C}$  dewpoint ( $-148^{\circ}\text{F}$  to  $+68^{\circ}\text{F}$  dewpoint),  $\text{g/m}^3$ , 0-9999 ppmv as well as 0-1000 lb/mmscf for natural gas. Selection of the displayed hygrometric unit is factory set but may be easily changed by the user. Dual alarm relay contacts are provided which are user configurable both in terms of setpoint and operating mode (i.e. NC or NO). Optionally, one or two additional relays can be fitted with Form A type contacts (see section 2.2.2 for details). Current output is standard and factory set at 4 - 20 mA, optional outputs are 0 - 20mA or 0 - 10 VDC.

The monitor has a pressure input channel to accept the signal from any standard 2-wire pressure transmitter. Pressure can be scaled and displayed to appropriate engineering units. The pressure signal can then be used to provide pressure compensation on the primary channel of lb/mmscf,  $\text{g/m}^3$  or ppmv.

## 1.3 Ceramic Technology Sensor

The Cermet II hygrometer utilizes the Kahn ceramic technology moisture sensor. This sensor is manufactured from metalized ceramics using thin and thick film technologies to produce a sensor, which is virtually chemically inert with inherently fast response, high calibration stability and high resilience to corrosive environments. The Cermet II hygrometer measures moisture by reading digital data sent from the intelligent micro-controller based ceramic moisture sensor.

## 1.4 Calibration

Calibration is performed using precision dewpoint generators and transfer standard optical hygrometers, which have been calibrated directly at the National Institute of Standards and Technology (**NIST**).

As with all precision measurement equipment, calibration integrity depends on regular verification. Kahn Instruments suggest that the instrument be returned to the Kahn Calibration Laboratory at least once a year for a re-calibration. Alternatively an exchange sensor can be ordered and simply installed by the user on-site to avoid costly downtime. In either case, calibration is inexpensive and ensures continued accurate operation of the instrument.

## **1.5 Manufacturing Quality**

Your hygrometer should reach you in perfect working condition. Rigorous procedures at every stage of production ensure that the materials of construction, manufacturing, calibration and final test procedures meet the requirements laid down by our Quality System.

## 2. PREPARATION

The Cermet II hygrometer is supplied with a full accessory package. Please check that all the following standard components are present in the packing box:

- 1) Monitor - Cermet II hygrometer
- 2) Moisture Sensor
- 3) Sensor cable assembly
- 4) Sensor seal (bonded seal type)
- 5) Power cable

Any additional items will be shown on the packing list.

### 2.1 Installing the Monitor

The monitor requires an operating environment of 0° C to 50° C, 0 to 90% RH.

The monitor case is designed for panel mounting. However, it can be used as a bench mounted device without any special preparation.

For panel mounting, a suitable cutout should be made in the panel to be used. A rectangular cutout of 92 x 45 mm (DIN 1/8) is necessary (see Figure 1. Panel Cutout). Optional NEMA 4 cover provides additional front panel protection for harsh environments.

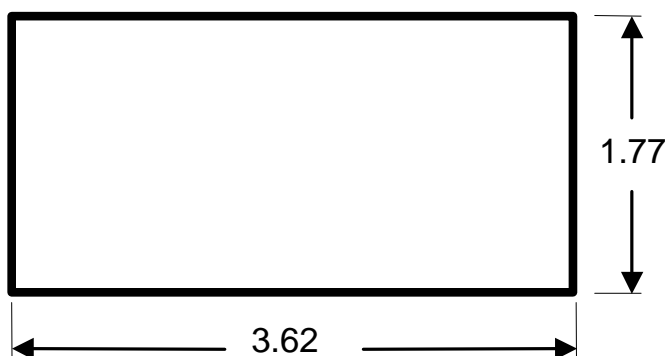

Figure 1. Panel Cutout

**NOTE:** A minimum depth behind the panel of 5.5" is required for the monitor, its connectors and wiring (see Figure 2. Case Dimensions).

The monitor should be inserted into the panel cutout from the front and secured using the two brackets with securing screws on the sides of the front case.

All electrical connections through the rear panel are made via plug and socket terminals to facilitate easy removal of the monitor when in service.

## 2.2 Electrical Connections

When the monitor is securely fastened in position, the electrical connections can be made to the back panel.

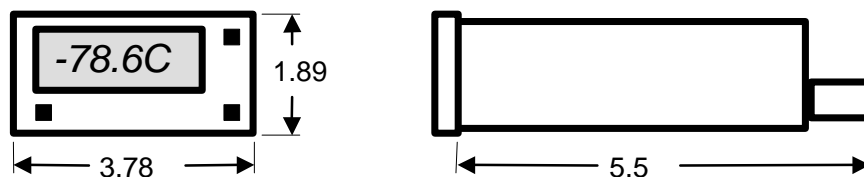

Figure 2. Case Dimensions

Figure 3 shows the connections for power, dewpoint sensor, alarm relays and analog output. These details are also repeated on the instrument itself. The exact factory setup of the monitor unit can also be obtained by reference to the connection details label that is applied to the monitor case.

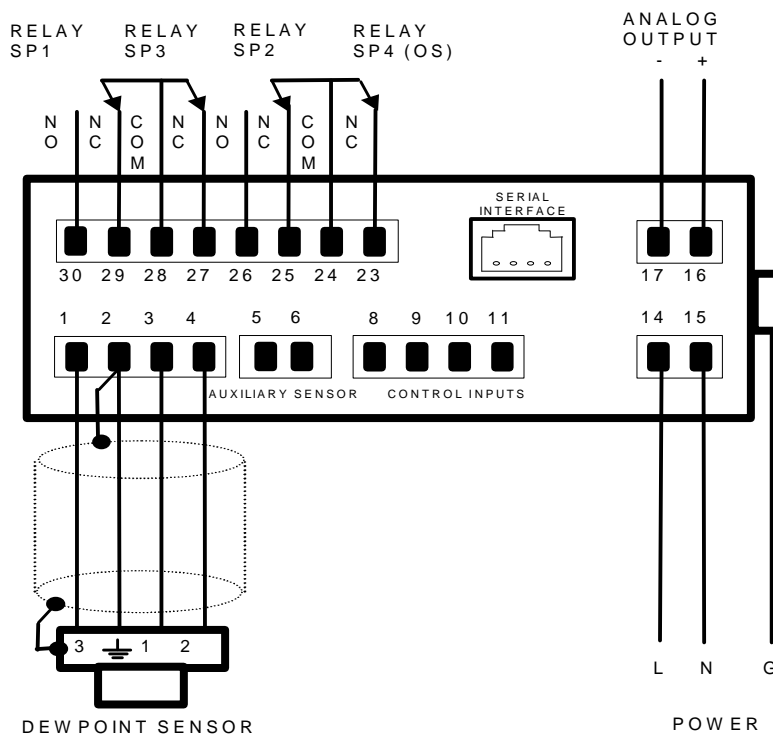

Figure 3. Instrument Wiring Diagram

### 2.2.1 Electrical Power

The power supply to the monitor may be one of the following:

- a) 115 VAC 50/60Hz - **factory default setting**
- b) 220 VAC 50/60Hz, 18-36 VAC and 9-60VDC - **optional**

The power supply voltage is indicated on the label located on the monitor.

As soon as power is connected at the rear of the monitor, the display will register a reading. The monitor is provided for continuous operation and does not feature a power ON/OFF switch.

### 2.2.2 Setpoint (Alarm) Relays

SP1 and SP2 are Form C relay contacts and can be connected as Normally Open (NO) or Normally Closed (NC). Contacts are rated 240 VAC/10 A or 24 VDC/8 A (non-inductive load).

Optional additional relays SP3 and SP4 have Form A relay contacts and are Normally Open only. Contacts are rated 240 VAC/5 A or 30 VDC/ 5 A (non-inductive load).

Configuration of setpoints is covered in section 3.3.

### 2.2.3 Analog Output

The monitor as standard provides a 4 to 20 mA (optionally: 0 to 20mA or 0-10VDC) linear output over the entire operating range of the instrument in the selected engineering units. The output can be digitally scaled to cover a partial range of the measurement parameter. See **CAL** (under setup codes) in Appendix 2.

The maximum load resistance that can be connected between pin 16(+) and pin 17(-) for a **CURRENT** output is 500 Ohms (No minimum).

The minimum load that can be connected to pin 16(+) and pin 17(-) for a **VOLTAGE** output is 5 kOhms (No maximum).

### 2.2.4 Digital Interface

The monitor can be equipped with an optional RS232 or RS485 digital interface. A two meter RS232 cable, terminated with a 9 way 'D' socket, is available on request.



## 2.3 Sensor Cable

The sensor cable should be connected to the monitor by its four wires as shown on Figure 3. The standard cable length is 6 feet. If additional cable length is required, it can be supplied on request.

If the customer prefers to use its own cable, then it is important that the cable meet the following specification: *a pair of 7/0.25mm (22 AWG.) stranded, copper conductors, insulated with polypropylene, twisted together with a common copper shield wire, wrapped in aluminized polyester tape and enclosed together with a second similar pair in a PVC outer sheath.*

## 2.4 Dewpoint Sensor Installation

Remove the protective cap from the sensor before installation and retain for future use.

The sensor is provided with a 5/8"-18 UNF mounting thread which makes it suitable for mounting either in its flow-through sensor sampling block or inserted directly into a pipe or duct. A bonded seal is provided to seal the sensor and installation interface. The sensor body is designed to mate with the bonded seal provided when using a 5/8" -18 UNF mounting thread only. The bonded seal should be placed over the sensor before it is screwed into the sampling location. This arrangement is designed for operation at pressures up to 5000 psig.

The sensor and sampling block are sufficiently light so that no special arrangements need be made to secure them providing they are connected into a stainless steel tubing system. If PTFE tubing is used, it may be necessary to secure the sample block against a suitable panel or wall using a spring clip or clamp.

The sensor requires an operating environment of  $-40^{\circ}\text{C}$  to  $+60^{\circ}\text{C}$  ( $-40^{\circ}\text{F}$  to  $+122^{\circ}\text{F}$ ) and uses a high integrity connector, which is suitable for outdoor use / harsh environments and is rated NEMA 4 (IP66).

Although the correct operation of the sensor is not sample flow rate dependent, it is important to insure that the flow velocity through the sample line which connects the sample source to the sampling block is high enough to avoid long time lags in response to changes in moisture at the sample source. We recommend that a flow rate of 1 to 5 liters per minute (2 to 10 SCFH) be set when the sensor is mounted in the standard sampling block. In direct insertion applications, a wide range of gas flow velocity past the sensor is acceptable: static to 10 meters per second (30 feet per second) when fitted with the standard 80-micron sintered sensor guard.

Finally, connect the sensor cable to the sensor using the four-pin connector already provided on the cable. The instrument is now ready for configuration and use.

### 3. INSTRUMENT SETUP

**NOTE:** When the instrument is first powered up the display may show a zero value for about 1 second, followed by a flashing "OPEN" message for approximately 5 seconds, before showing a dewpoint value. This is normal and does not indicate a problem with the instrument.

There are two levels of operation, USER and ADVANCED.

User allows:

- Changing of the setpoint values;
- Monitoring of the min/max values.

Advanced programming allows setting of the following options:

- advanced setpoint programming;
- analog output calibration and scaling;
- auxiliary (optional) channel setup;
- setting the engineering units;
- sensor connection fault relay setup;
- other related advanced functions.

To access the advanced programming press and release SETUP and  $\bar{Y}$  simultaneously to scroll through the menus.

#### 3.1 Setup Security Feature

To prevent unauthorized access to the internal settings, the monitor is equipped with two DIP-switches located on the display board of the monitor, which can be accessed underneath of the faceplate (refer to Figure 4. Location of the LOCKOUT Switches.). The PROGRAM LOCKOUT switch SW2 is responsible for enabling or disabling the code programming mode. The SETPOINT LOCKOUT switch SW1 enables or disables the setpoint programming. OFF position of either switch will enable that mode, ON position will disable that mode.

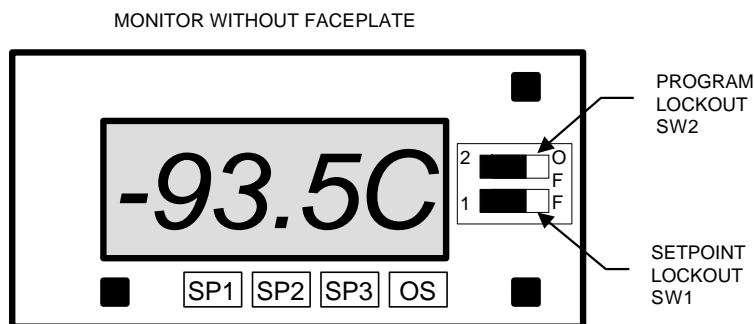

Figure 4. Location of the LOCKOUT Switches.

### 3.2 Selecting the Engineering Units

Enter the PROGRAM UNLOCK mode as described in Section 3.1 Setup Security Feature, and press SETUP and  $\bar{Y}$  to scroll through the menus.

The monitor can display Dewpoint in  $^{\circ}\text{C}$  or  $^{\circ}\text{F}$ , ppmv, lb/mmscf or  $\text{g}/\text{m}^3$ . The selection of these units is achieved by setting CODE 4 and CODE 7 as shown below: (See Appendix 2, CODE 4 & CODE 7 for full details).

To display Dewpoint set CODE 7	to	000
To display Dewpoint in $^{\circ}\text{C}$ set CODE 4	to	000
To display Dewpoint in $^{\circ}\text{F}$ set CODE 4	to	010
To display ppmv set CODE 7	to	100
To display lb/mmscf set CODE 7	to	200
To display $\text{g}/\text{m}^3$ set CODE 7	to	300

To set the range and resolution for ppmv, lb/mmscf and  $\text{g}/\text{m}^3$ , set digit 3 of CODE 7 to:

<b>0</b>	1 – 9999
<b>1</b>	0.1 – 999.9
<b>2</b>	0.01 – 99.99
<b>3</b>	0.001 – 9.999

For example, by setting CODE 7 to 102, the monitor displays ppmv with a resolution of 0.01 to a maximum of 99.99, above which, message oVER will be displayed.

Notice, that regardless of the engineering unit selected, pressing the  $\bar{Y}$  button will switch the display to indicate the dewpoint in degrees C. Pressing the SETUP button will return the display into a previous indication mode.

### 3.3 Changing the Setpoint Values

Before amending the setpoint values, make sure that the monitor is in the SETPOINT UNLOCK mode, as described in 3.1 Setup Security Feature.

Press SETUP and  $\downarrow$  simultaneously to gain access to the setpoint codes.

The setpoints of the relays are set by setting **SP<sub>n</sub>** (where n = 1 to 4 and represent SP1 to 4), to the required level. The units of the setpoints change according to the source of the setpoints, i.e. if the indicator is displaying ppmv, then the setpoints are set in ppmv.

For the relays to be energized above the setpoint **SPC<sub>n</sub> = 0xx**.

For the relays to be energized below the setpoint **SPC<sub>n</sub> = 1xx**.

The source of relay setpoints are set by setting digit 2 of **SPC\_n** i.e. **xnx** as shown below:

- 0 Displayed value **(DEFAULT)**
- 1 Dewpoint
- 2 Pressure
- 3 Sensor connection fault
- 4 Sensor failure
- 5 Thermistor failure
- 6 All sensor faults

For example; if you wish the relay to trip at a certain dewpoint value while the indicator is displaying ppmv, then **SPC\_n = x1x**, or if the relay is to trip if an failure occurs with the sensor, then **SPC\_n = x4x**.

The secondary relay function is set by digit 3 of **SPC\_n** i.e. **xxn** as shown below:

- 0 No function **(DEFAULT)**
- 1 Relay latched
- 2 De-energize relay
- 3 No function
- 4 Relay de-energized for sensor connection fault
- 5 Relay energized for sensor connection fault
- 6 Relay toggles at 1Hz for sensor connection fault
- 7 Setup for hysteresis, delay type and make/break delay times

For example, if you wish the relay to trip above the setpoint using the displayed value, but to remain latched, then **SPC\_n = 001**. It will then remain latched until the supply to the indicator is removed or **SPC\_n = 002**.

The function of the relay annunciators is set by digit 1 of CODE 1 i.e. **nxx**. As shown below:

- 0 LED annunciators always OFF
- 1 LED annunciators ON when relays are de-energized
- 2 LED annunciators ON when relays are energized **(DEFAULT)**

### **Hysteresis, Make/Break Delay & Delay Type**

Associated with each setpoint is a Hysteresis Value, Make delay time, Break delay time and a delay type. To gain access to these parameters, set **SPC\_n = xx7**, and to scroll the features press  $\uparrow$  or  $\downarrow$ .

The hysteresis value is a value that the relay trips above and below the nominal setpoint. For example, if SP1 is set to -10.0 and the HYST is set to 2.0 and the relay is set to energize above the setpoint, then the relay will energize when the setpoint source rises above -8.0 and is de-energized when the setpoint source falls below -12.0

The Make delay is the delay between the setpoint being reached and the relay energizing. For example, if **M\_d = 0.02.30** then the relay will be energized 2 minutes and thirty seconds after the trip point has been reached.

The Break delay is the delay between the relay being energized and it de-energizing. For example, if **b\_d = 0.01.12** then when the relay is energized it will remain energized for 1 minute and 12 seconds, after which it will be de-energized.

The maximum make and break delay time is 9 hours 6mins and 6secs in increments of 1 second.

The setpoint can have four different delay types:- **NorM** (normal), **rEPt** (repeat), **1Shot**, and **PuLSE**.

If **deLAY = NorM** then the relay will function normally with the inclusion of the time delays.

If **dELAY = rEPt** then the make and break delays will repeat continually until the setpoint source goes to a level to deactivate the setpoint. For example, if the make delay = 10 sec & break delay = 5 sec, then after the trip point is reached, the relay will energize after 10secs and remain energized for 5secs after which it will de-energize for 10 sec and then energize for 5 sec etc.

If **dELAY = PuLSE** then if using the make and break times mentioned above, the relay will energize after 10secs, de-energize after 5secs and remain de-energized.

If **dELAY = 1Shot** then if using the make and break times mentioned above, the relay will energize after 10secs and remain energized.

### 3.4 Analog Output Scaling

Enter the PROGRAM UNLOCK mode as described in 3.1, press SETUP then  $\bar{Y}$ , then SETUP again. Now use  $\bar{Y}$  and  $\beta$  to scroll through to the CAL menu.

The analog output can be scaled by setting CAL to 061 and setting the zero value to the required output at 4mA (or 0V) and the full scale value to the output required at 20mA (or 10V).

For example, if the output is required to go from  $-90.0^{\circ}\text{Cdp}$  at 4mA to  $+10^{\circ}\text{Cdp}$  at 20mA then set Zero to  $-90.0$  and F.S. to 10.0

To exit the CAL menu, set CAL to 000 and use  $\bar{Y}$  to scroll through the menus.

In order for the analog output to represent the value displayed by the indicator, i.e. Dewpoint, ppmv, lb/mmscf or  $\text{g/m}^3$ , then set CODE 3 to 000. The values for ZERO and

F.S. are then set in the appropriate units i.e. in ppmv when ppmv is the value being displayed.

If the analog output is required to represent dewpoint while the unit is displaying one of the calculated values (PPM(V), LB/MMSCF or  $g/m^3$ ) then set CODE 3 to 010.

If the analog output is required to represent pressure, then set CODE 3 to 020.

### 3.5 Display Brightness Adjustment

To adjust the display brightness:

- press SETUP and  $\bar{Y}$  buttons simultaneously, the display toggles between [bri] and [5], where 5 is default setting;

- adjust the display brightness required (from 0 to 7) by using  $\bar{Y}$  or  $\beta$  buttons, then press SETUP several times to exit the programming mode.

### 3.6 Digital Communications

The monitor can be supplied with an optional ASCII RS232 or RS485 serial interface.

The communication settings can be found by setting CAL to 100, then pressing the SETUP button once and then  $\bar{Y}$  and  $\beta$  to change the baud rate. Baud rates are 300, 600, 1200, 2400, 4800, 9600, 19,200 and 57.6K. Press the SETUP button again to advance to the parity bit and then  $\bar{Y}$  and  $\beta$  to change the parity bit. Parity settings are odd, even or off. Press the SETUP button again to advance to the address settings. Address settings are 0 to 255. Note, address 0 is not a valid RS485 address. Press the SETUP button again to return to CAL.

The communications uses the following default protocol:

Baud rate	9600
Data bits	8
Parity	none
Flow control	Xon/Xoff

The message to read and write to the monitor follows the following format:

- 1) Start Character  
"s" or "S" for the start character (must be first character in string).
- 2) Meter Address  
An ASCII number from "0" to "255" for the meter address. If the character following the start character is not an ASCII number, then address 0 is assumed. All meters respond to address 0.

### 3) Read/Write Command

The next character must be an ASCII "R" or "r" for read, or an ASCII "W" or "w" for write. Any other character will abort the operation.

### 4) Register Address

The register address for the read/write operation is specified next. It can be either an ASCII number from "0" to "255" or registers 1 - 18 can be accessed by entering an ASCII letter from "A" to "R" (or "a" to "r", not case sensitive). If the address character is omitted in a read command, the meter will always respond with the data value currently on the display. (The register address must be specified for a write command).

### 5) Separator Character

After the register address in a write command, the next character must be something other than an ASCII number. This is used to separate the register address from the data value. It can be a space or a "," or any other character except a "\$" or a "\*".

### 6) Data Value

After the separator character, the data value is sent. It must be an ASCII number in the range of "-32766" to "32766".

### 7) Message Terminator

The last character in the message is the message terminator and this must be either a "\$" or a "\*". If the "\$" is used as a terminator, a minimum delay of 50mS is inserted before a reply is sent. If the "\*" is used as a terminator, a minimum delay of 2mS is inserted before a reply is sent. (the "\$" and "\*" characters must not appear anywhere else in the message string).

#### Examples:

SR\$	Read display value, 50mS delay, all meters respond.
s15r\$	Read display value, 50mS delay, meter address 15 responds.
Sr130*	Read Code 1 setting, 2mS delay, all meters respond.
s2wb-10000\$	Write -10000 to the display register of meter address 2, 50mS delay.
SW65 200\$	Write 200 to the SP1 Hysteresis register, 50mS delay, all meters respond.
s10w148,7*	Change brightness to 7 on meter address 10, 2mS delay.
sr6\$	Reads SP1
sw6-100\$	Sets SP1 to -10.0
sr5\$	Reads pressure value

A full list of the register that can be read or written to can be found in Appendix 1.

## 4. PRESSURE COMPENSATION

Enter the PROGRAM UNLOCK mode as described in 3.1.

The monitor has the ability to measure pressure in order to provide a pressure compensated value for ppmv, lb/mmscf or g/m<sup>3</sup>.

### 4.1 Using an Optional Pressure Transducer

In order to enable the use of a pressure transducer, set CODE 4 to 100 (dual channel mode), by pressing SETUP and Ÿ to scroll through the menus.

If you wish to display Dewpoint while measuring pressure, then set CODE 4 to 100 to show Dewpoint in °C or 110 in °F.

To display pressure in PSIG set CODE 6 to 000, or set CODE 6 to 100 to display in BARG.

#### Manual Pressure Input Calibration

The pressure input channel needs to be calibrated in order to match the range of the pressure transducer. This is achieved by setting CAL to 012 and entering values for offset OFF\_2 and scale SCA\_2.

$$SCA\_2 = 0.0062 \text{ per } 100 \text{ PSIG}$$

$$OFF\_2 = \text{pressure range} - ((20,000 \times (\text{pressure range}/1000))/16)$$

For example, for a pressure transducer with a range of 0 to 1000 PSIG:

$$SCA\_2 = 0.0062 \times 10 = 0.0620$$

$$OFF\_2 = 1000 - ((20,000 \times (1000/1000))/16) = 1000 - 1250 = -250$$

If you are using a pressure transducer in BARG, then you have to convert the value to PSIG by multiplying it by 14.5.

For a pressure transducer with a range of 0 to 100 BARG:

$$100 \text{ BARG} = 1450 \text{ PSIG}$$

$$SCA\_2 = 0.0062 \times 14.5 = 0.0899$$

$$OFF\_2 = 1450 - ((20,000 \times (1450/1000))/16) = 1450 - 1813 = -363$$

To exit the CAL menu, set CAL to 000 and press Ÿ to scroll through the menus.



## **Automatic Pressure Input Calibration**

The pressure input can alternatively be calibrated using a 2-wire transducer simulator with 4 and 20mA output. To do this, connect the simulator between pin 6 (+ve) and pin 5 (-ve).

Set CAL to 022 and press SETUP. The monitor will then display ZERo and flash 0. Set the simulator output to 4.0mA and press SETUP to set 0 at 4mA.

Press SETUP and the monitor will display SPAn and flash the full scale pressure value. Set the simulator output to 20.0mA and use the  $\bar{Y}$  &  $\beta$  buttons to set the required pressure range. Then press SETUP to set the required pressure for 20.0mA.

Set CAL to 000 and press  $\bar{Y}$  to leave the menus.

## **4.2 Using a Fixed Pressure Input in Single Channel Mode**

In order to display pressure compensated values of ppmv, lb/mmscf and  $g/m^3$  without the use of a pressure transducer, then this can be achieved by entering the pressure value manually.

Enter the PROGRAM UNLOCK mode. Use SETUP and  $\bar{Y}$  to scroll through the menus and select code 7.

Select the required pressure compensated value, i.e. CODE 7 = 1xx for ppmv, 2xx for lb/mmscf or 3xx for  $g/m^3$ , and CAL = 052.

Exit the menus and exit the PROGRAM UNLOCK MODE. Press SETUP for two seconds, and the display will show the set pressure. To change the pressure, use  $\bar{Y}$  and  $\beta$  and then press SETUP.

## **4.3 Optional Pressure Transducer Connection**

The monitor provides excitation voltage (24VDC @ 20mA) for an auxiliary 2-wire transmitter used in the dual channel configuration. Connect (+) of the transmitter to pin 6 of the monitor, (-) of the transmitter to pin 5 of the monitor. Refer to Figure 5. Wiring Diagram for details.

Press  $\beta$  button to monitor the pressure value. Press  $\bar{Y}$  button to monitor the dewpoint value. Press SETUP button to monitor PPMV or LB/MMSCF.

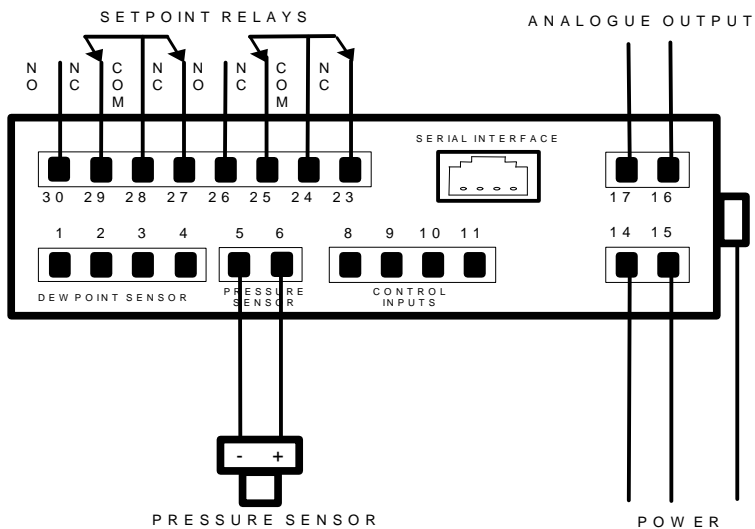

Figure 5. Wiring Diagram for Pressure Sensor

## 5. OPERATION

Operation of the Cermet II hygrometer is very simple assuming that the necessary precautions are taken to protect the sensor from damage. Statistical information indicates that the vast majority of failures are caused either by incorrect sampling methods, sampling positions or inadequate protection against dangerous substances.

### 5.1 Sampling Hints

The ceramic sensor is designed to operate in a flowing gas stream. The sensor can be mounted directly into a flowing gas stream in a duct or pipe, provided there is no form of contamination within the pipe/duct, which will damage the sensor. A sensor sampling block is available which allows a small sample of process gas to be diverted past the sensor before returning to the main gas stream or being bled off to atmosphere.

The general rules to be adhered to when arranging a sampling system are as follows:

#### Be Sure the Sample is Representative of the Gas Under Test

The sample point should be as close to the critical measurement point as possible. For example, in a glove box application, mount the sensor at the exit of the glove box, not at the gas entry point.

#### Minimize Dead Space in Sample Lines

Try to avoid too many tee pieces or unnecessary tubing. Where possible, build up a sampling system specifically for the job, and do not use tubing previously installed for another application. Dead space in sample lines causes moisture entrapment points, increased system response times or measurement errors as the trapped moisture is released into passing sample gas causing an increase in partial vapor pressure.

#### Remove Any Particulate Matter or Oil from the Gas Sample

Particulates at high velocity can damage the sensor. Similarly, at low velocity, they may "blind" the sensor and reduce its response speed. If particulates such as degraded desiccant or pipe scale and rust are likely to be present in the sample gas, use a particulate in-line filter. Kahn technical sales personnel will be happy to give advice.

#### Use High Quality Sample Tube and Fittings

We would recommend that, wherever possible, stainless steel tubing and fittings be used. This is particularly important at low dewpoints since other metals have hygroscopic characteristics and adsorb moisture on the tubing walls, slowing down response and, in extreme circumstances, giving false readings. For temporary

applications or where stainless steel tubing is not feasible, use high quality thick-walled PTFE tubing, which exhibits similar characteristics to stainless steel.

Always use the shortest run of tubing possible between two points. Use the lowest diameter tubing possible to reduce response time, but take care not to induce pressure differentials by aiming for too high a flow rate through small diameter tubing. A sampling flow between 1 and 5 liters per minute (2-10 SCFH) will be satisfactory for the ceramic sensor to operate correctly.

## 5.2 Response Characteristic

Many factors will affect the response speed of the Cermet II hygrometer. However, your task will be made simpler if, like the vast majority of applications, your Cermet II hygrometer is being used to detect an increase in moisture content of your sample gas. It is much easier for the sensor to detect an increase in moisture content than to respond to a decrease. This is similar in principle to the way it is easy to make a sponge wet, but more difficult to dry it out afterwards. Most materials which are not hydrophobic have similar characteristics and it is these which prevent the Cermet II hygrometer from responding in a real-life application as quickly as under test conditions.

However, since response characteristics from dry to wet are orders of magnitude faster than from wet to dry, the effective response speed of the system to leaks, ingress of moisture, etc. is very fast indeed. In real life applications such as dryer monitoring or glove box monitoring the sensor will respond in a few seconds to an increase in moisture content.

In practice, the time taken to dry down a sensor from ambient conditions to the operational dewpoint level of the process will normally be shorter than the time taken to dry down the process itself. Therefore, when the sensor is installed into the system prior to system start-up, there is normally no time lag before representative test results are obtained.

If a new sensor is installed into an operational system, for example a gas dryer exit pipe via a sampling line with particulate filter, then typically fifteen to thirty minutes should be allowed for the tubing, filter and sensor to reach equilibrium with the sample gas passing through.

## 5.3 Which Gases to Measure?

The Cermet II hygrometer, by nature of its design, is suitable for measurement of the moisture content of a wide variety of gases. In general, if the gas (in conjunction with water vapor) is not corrosive to ceramics or base metals then it will be suitable for measurement by the Cermet II hygrometer. However, gases containing entrained solids or hydrocarbon mists should be filtered upstream of the ceramic sensor. High purity gases will not be contaminated by the ceramic sensor. It has no components that are

likely to outgas (epoxy, plastics, etc.) and, therefore, is safe for use in critical semiconductor and fiber optic applications.

High pressure samples may be measured up to a maximum of 5000 psig. Make sure that the correct fittings are used and that the bonded seal provided is used to seal the radial face of the sensor/sensor block seal.

Similarly, the sensor is suitable for measuring samples below atmospheric pressure. Care should be taken at joints and pipe fittings that no leak exists which could allow ambient air to contaminate the sample gas. If there is doubt, a standard leak test procedure should be employed (helium or vacuum seal).

## 6. TECHNICAL SPECIFICATIONS

### 6.1 Monitor

<b>Display:</b>	5 digit LED
<b>Dewpoint Measurement Ranges:</b>	-100° C to +20° C, -148° F to +68° F, 0 to 9999 ppmv, 0 to 1000 lb/mmscf, g/m <sup>3</sup> user selectable.
<b>Pressure input channel:</b>	4-20mA input scaleable to any engineering units.
<b>Electronic accuracy:</b>	PPMV range ±1% of reading, LB/MMSCF range ±1% of reading, secondary channel ±0.5% FS.
<b>Outputs:</b>	4-20mA as standard or 0-20mA optional (max load 500 ohms) or 0-10V optional (min load 5 kOhms), spanned to full calibration range, scaleable by user.
<b>Alarm Relays:</b>	<p>Two relays SP1 and SP2 are standard. Control action and setpoint are user programmable. Form C contacts rated 10 A, 240 VAC or 8 A 24 VDC non-inductive load.</p> <p>Relays SP3 and SP4 (OS) are optional. Control action and setpoint are user programmable. Form A contacts rated 5 A, 240 VAC or 5 A, 30 VDC non-inductive load.</p>
<b>Operating environment:</b>	0° to +50° C, 0 to 90%RH.
<b>Power supply:</b>	115 VAC, 50/60 Hz or 220 AC 50/60 Hz standard. Optionally: 18-36 VAC or 9-60VDC.
<b>Power consumption:</b>	Max 10 Watts.
<b>Power connection:</b>	6 feet, 3 wire.
<b>Weight:</b>	1.32 lbs.
<b>Sensor cable:</b>	A pair of 7/0.25mm (22 AWG.) stranded, copper conductors, insulated with polypropylene, twisted together with a common copper shield wire, wrapped in aluminized polyester tape and enclosed together with a second similar pair in a PVC outer sheath. Fitted with sensor connector and terminations for monitor. Maximum length 1000 meters.
<b>Environmental protection:</b>	IP54 / NEMA 12. Optional protection cover to IP66 / NEMA 4.

## 6.2 Sensor

<b>Type:</b>	Kahn Ceramic Sensor.
<b>Calibration range:</b>	-100° C to +20° C.
<b>Interchangeability:</b>	Fully interchangeable sensors.
<b>Dewpoint Accuracy:</b>	±2.0° C between -60° C & -100° C ±1.0° C between +20° C & -60° C (Or equivalent for other ranges).
<b>Operating temperature:</b>	-40°C to +60°C.
<b>Temperature coefficients:</b>	Temperature compensated from -20°C to +40°C
<b>Operating vacuum / pressure:</b>	10e <sup>-6</sup> Bara vacuum to 5000 psig.
<b>Flow rate:</b>	Recommended 1-5 liters per minute (2-10 SCFH) when sensor is mounted in standard sampling block or, for direct insertion applications: Static to 10 meters per second, when a 80 micron sintered guard is fitted.
<b>Traceable certification:</b>	-75°C to +20°C dewpoint traceable to <b>National Institute of Standards and Technology</b> . For dewpoints < -75°C direct reference to a fundamental chilled mirror dewpointmeter.
<b>Environmental protection:</b>	NEMA 4 / IP66.
<b>Weight:</b>	0.33 lbs

## 7. MAINTENANCE

Routine maintenance of the Cermet II hygrometer is confined to regular re-calibrations. This work can only be done by exposure of the moisture sensor to sample gases of known moisture content. Calibration services traceable to the **National Institute of Standards and Technology** are provided by Kahn Instruments.

The frequency of re-calibrations required in order to maintain the performance of the Cermet II hygrometer is primarily dependent on the composition of the gas to which the sensor is exposed: i.e. content of liquid and particulate contaminants, corrosive elements, etc. In most applications, annual re-calibration ensures that the stated accuracy of the Cermet II hygrometer is maintained.

Ceramic sensors are fully interchangeable with hygrometers. Maintaining the measurement accuracy of the Cermet II hygrometer in applications where it is installed as a permanent on-line monitor is, therefore, simply a case of exchanging the sensor for a freshly calibrated one, which will be supplied with a traceable certificate of calibration. Sensor interchangeability is also not affected by sensor cable length; therefore, this method of maintaining calibration can be used for all sensor installations.

For applications where the Cermet II hygrometer is not required for continuous operation, re-calibration of Cermet II hygrometer can be achieved by return of the complete instrument - monitor, sensor and interconnecting cable - to Kahn Instruments.



## APPENDIX 1

### Register settings accessible by digital communication

Register number	Function	Read only
1	Alarm Status	
2	N/A	
3	Processed Data – Result	✓
4	Processed Data – Channel 1 (dewpoint)	✓
5	Processed Data – Channel 2 (pressure)	✓
6	Setpoint 1	
7	Setpoint 2	
8	Setpoint 3	
9	Setpoint 4	
10 to 23	N/A	
24	Scale Value – Result	
25	Scale Value – Channel 1	
26	Scale Value – Channel 2	
27	Offset Value – Result	
28	Offset Value – Channel 1	
29	Offset Value – Channel 2	
30 to 33	N/A	
34	D/A Zero – Analogue O/P 1	
35	N/A	
36	D/A Full Scale – Analogue O/P 1	
37 to 64	N/A	
65	Hysteresis - Setpoint 1	
66	Hysteresis - Setpoint 2	
67	Hysteresis - Setpoint 3	
68	Hysteresis - Setpoint 4	
69 to 70	N/A	
71	Make Delay - Setpoint 1	
72	Make Delay - Setpoint 2	
73	Make Delay - Setpoint 3	
74	Make Delay - Setpoint 4	
75 to 76	N/A	
77	Break Delay - Setpoint 1	
78	Break Delay - Setpoint 2	
79	Break Delay - Setpoint 3	
80	Break Delay - Setpoint 4	
81 to 128	N/A	
129	Cal Mode	
130	Code 1	
131	Code 2	
132	Code 3	

133	Code 4	
134	Code 5	
135	Code 6	
136	Code 7	
137	Code 8	
138 to 141	Reserved	
142	Setpoint 1 Control Register	
143	Setpoint 2 Control Register	
144	Setpoint 3 Control Register	
145	Setpoint 4 Control Register	
146 to 147	N/A	
148	Brightness	
149	Baud rate Settings	
150	Serial Address	
151 to 152	N/A	
153	Model Number	✓
154	Version Number	✓
155 to 192	N/A	
193	Delay Type – Setpoint 1	
194	Delay Type – Setpoint 2	
195	Delay Type – Setpoint 3	
196	Delay Type – Setpoint 4	

## APPENDIX 2

### Setup Codes

#### CAL (Calibration modes for input and output.)

1<sup>st</sup> digit (left most): Calibration mode

<b>Digit:</b>	<b>Function</b>
0	Calibration functions as per 2 <sup>nd</sup> and 3 <sup>rd</sup> digit
1	Set baud rate, parity and serial address

2<sup>nd</sup> digit: Calibration function

<b>Digit:</b>	<b>Function</b>
0	No function
1	Manual calibration (channel as per 3 <sup>rd</sup> digit)
2 to 4	N/A
5	Manual adjust
6	Analog output scaling (analogue channel as per 3 <sup>rd</sup> digit)
7	N/A

3<sup>rd</sup> digit: Object for calibration

<b>Digit:</b>	<b>Function</b>
0	No function
1	Processed result (dewpoint, ppmv, lb/mm <sup>3</sup> scf, g/m <sup>3</sup> )
2	Pressure input

**DEFAULT VALUE = 052**

## **CODE 1 (Tendency Indication, Additional LED's, Display data source, Display flashing, Decimal points, Display rounding)**

1<sup>st</sup> digit (left most): additional LED's

<b>Digit:</b>	<b>Function</b>
0	LED annunciators are always off
1	LED annunciators are on when relays are de-energized
2	LED annunciators are on when relays are energized
3	N/A

2<sup>nd</sup> digit: Display data source

<b>Digit:</b>	<b>Function</b>
0	Processed data - result (dewpoint, ppmv, lb/mmscf, g/m <sup>3</sup> )
1	Processed data - channel 1 (dewpoint only)
2	Processed data - pressure
3 to 7	N/A

3<sup>rd</sup> digit: 0 only

**DEFAULT VALUE = 200**

## **CODE 2 (Totalizer functions & calibration of linearization tables)**

Access denied.

**DEFAULT VALUE = 000**

## **CODE 3 (Serial mode and analog output source)**

Access denied.

**DEFAULT VALUE = 000**

## **CODE 4 (Channel 1, Measurement task, sampling rate)**

1<sup>st</sup> digit (left most): Analog sample rate

<b>Digit:</b>	<b>Function</b>
0	Single channel (60Hz)
1	Dual channel (60Hz)
2	Single channel (50Hz)
3	Dual channel (50Hz)

2<sup>nd</sup> digit: Analog output 1 source

<b>Digit:</b>	<b>Function</b>
0	Dewpoint in degrees C
1	Dewpoint in degrees F

3<sup>rd</sup> digit: 0 only

**DEFAULT VALUE = 010**

### **CODE 5 (Channel 1 Processing)**

Access denied

**DEFAULT VALUE = 000**

### **CODE 6 ( Channel 2, Measurement task)**

1<sup>st</sup> digit (left most): Measurement task

<b>Digit:</b>	<b>Function</b>
0	Pressure in PSIG
1	Pressure in BARG
2	N/A

2<sup>nd</sup> digit: 0 only

3<sup>rd</sup> digit: 0 only

**DEFAULT VALUE = 000**

### **CODE 7 (Result processing)**

1<sup>st</sup> digit (left most): Measurement task

<b>Digit:</b>	<b>Function</b>
0	Dewpoint
1	ppmv
2	lb/mmscf
3	g/m <sup>3</sup>

2<sup>nd</sup> digit: 0 only

3<sup>rd</sup> digit: Range for result

<b>Digit:</b>	<b>Function</b>
0	1 – 9999
1	0.1 – 999.9
2	0.01 – 99.99
3	0.001 – 9.999

**DEFAULT VALUE = 000**

## **CODE 8 (Data logging and print mode options)**

Access denied.

**DEFAULT VALUE = 000**

## **SPC (Setpoint control 1 – 6, accessed from SETUP/Down menu after setpoints)**

### **Relay latching, relay setup, source**

1<sup>st</sup> digit (left most): Relay sense

<b>Digit:</b>	<b>Function</b>
0	Relay energized above setpoint value
1	Relay energized below setpoint value
2 to 3	N/A

2<sup>nd</sup> digit: Setpoint source

<b>Digit:</b>	<b>Function</b>
0	Processed result data (dewpoint, ppmv, lb/mm <sup>3</sup> scf, g/m <sup>3</sup> )
1	Dewpoint only
2	Pressure
3	Open sensor connection
4	Open / short circuit sensor
5	Open / short circuit thermistor
6	All sensor faults

3<sup>rd</sup> digit: Setpoint function for SP1 – SP4

<b>Digit:</b>	<b>Function</b>
0	No function
1	Relay latched
2	De-energized relay
3	N/A
4	Relay off for open sensor connection

- 5 Relay on for open sensor connection
- 6 Relay toggles at 1Hz for sensor connection fault
- 7 Setup hysteresis, make/break delay and delay type

**DEFAULT VALUE = 000**

## APPENDIX 3

### Error Messages

The table below represents the possible error messages that can be seen on the hygrometer monitor under different conditions.

<b>Error message</b>	<b>Possible cause</b>	<b>Action</b>
Under	1. Measured dewpoint is below the measurement range (-100°C/-148°F)	Contact Kahn Instruments regarding your application
	2. Sensor is out of calibration or damaged	Contact Kahn Instruments for sensor repair or recalibration
Over	1. Measured dewpoint is above the measurement range (+20°C/+68°F)	Contact Kahn Instruments regarding your application
	2. Sensor was in contact with liquid water	Dry the sensor out with a stream of dry gas
	3. Sensor is out of calibration or damaged	Contact Kahn Instruments for sensor repair or recalibration
	4. Sensor is contaminated	Contact Kahn Instruments for sensor repair and application assistance
Open	1. Bad electrical connection between sensor and monitor	Verify connectivity of the sensor cable
	2. Internal sensor failure	Contact Kahn Instruments for sensor repair
	3. Internal monitor failure	Contact Kahn Instruments for monitor repair
Fail	Internal sensor failure	Contact Kahn Instruments for sensor repair
ErrE	Internal monitor temporary memory corruption due to unusually high power voltage spike	Perform the following monitor resetting procedure: 1. Turn the power OFF. 2. Press and hold the <b>Y</b> and <b>B</b> buttons. 3. Turn the power ON 4. Release the <b>Y</b> and <b>B</b> buttons. 5. Verify the monitor settings (alarm setpoints, output scaling, etc.)